

# **OpenCore**

## Reference Manual

[2019.05.03]

# Contents

<b>1</b>	<b>Introduction</b>	<b>3</b>
1.1	Known defects . . . . .	3
<b>2</b>	<b>Generic Terms</b>	<b>4</b>
<b>3</b>	<b>Overview</b>	<b>5</b>
3.1	Configuration Terms . . . . .	5
3.2	Configuration Processing . . . . .	5
3.3	Configuration Structure . . . . .	6
3.4	Directory Structure . . . . .	6
3.5	Contribution . . . . .	7
<b>4</b>	<b>ACPI</b>	<b>9</b>
4.1	Introduction . . . . .	9
4.2	Properties . . . . .	9
4.3	Add Properties . . . . .	9
4.4	Block Properties . . . . .	10
4.5	Patch Properties . . . . .	10
4.6	Quirks Properties . . . . .	11
<b>5</b>	<b>DeviceProperties</b>	<b>13</b>
5.1	Introduction . . . . .	13
5.2	Properties . . . . .	13
5.3	Common Properties . . . . .	13
<b>6</b>	<b>Kernel</b>	<b>14</b>
6.1	Introduction . . . . .	14
6.2	Properties . . . . .	14
6.3	Add Properties . . . . .	14
6.4	Block Properties . . . . .	15
6.5	Patch Properties . . . . .	15
6.6	Quirks Properties . . . . .	16
<b>7</b>	<b>Misc</b>	<b>18</b>
7.1	Introduction . . . . .	18
7.2	Properties . . . . .	18
7.3	Boot Properties . . . . .	18
7.4	Debug Properties . . . . .	19
7.5	Security Properties . . . . .	20
<b>8</b>	<b>NVRAM</b>	<b>22</b>
8.1	Introduction . . . . .	22
8.2	Properties . . . . .	22
8.3	Mandatory Variables . . . . .	22
8.4	Recommended Variables . . . . .	23
8.5	Other Variables . . . . .	23
<b>9</b>	<b>PlatformInfo</b>	<b>24</b>
9.1	Properties . . . . .	24
9.2	Generic Properties . . . . .	25
9.3	DataHub Properties . . . . .	25
9.4	PlatformNVRAM Properties . . . . .	27
9.5	SMBIOS Properties . . . . .	27
<b>10</b>	<b>UEFI</b>	<b>32</b>
10.1	Introduction . . . . .	32

10.2 Properties . . . . .	32
10.3 Protocols Properties . . . . .	33
10.4 Quirks Properties . . . . .	33
<b>11 Troubleshooting</b>	<b>35</b>
11.1 Tips and Tricks . . . . .	35

# 1 Introduction

This document provides information on OpenCore user configuration file format used to setup the correct functioning of macOS operating system.

## 1.1 Known defects

For OpenCore issues please refer to Acidanthera Bugtracker. Currently this file has the following entries not completed:

- Not all NVRAM variables are properly described (e.g. boot-args).

## 2 Generic Terms

- **plist** — Subset of ASCII Property List format written in XML, also known as XML plist format version 1. Uniform Type Identifier (UTI): `com.apple.property-list`. Plists consist of **plist objects**, which are combined to form a hierarchical structure. Due to plist format not being well-defined, all the definitions of this document may only be applied after plist is considered valid by running `plutil -lint`. External references: <https://www.apple.com/DTDs/PropertyList-1.0.dtd>, `man plutil`.
- **plist type** — plist collections (**plist array**, **plist dictionary**, **plist key**) and primitives (**plist string**, **plist data**, **plist date**, **plist boolean**, **plist integer**, **plist real**).
- **plist object** — definite realisation of **plist type**, which may be interpreted as value.
- **plist array** — array-like collection, conforms to **array**. Consists of zero or more **plist objects**.
- **plist dictionary** — map-like (associative array) collection, conforms to **dict**. Consists of zero or more **plist keys**.
- **plist key** — contains one **plist object** going by the name of **plist key**, conforms to **key**. Consists of printable 7-bit ASCII characters.
- **plist string** — printable 7-bit ASCII string, conforms to **string**.
- **plist data** — base64-encoded blob, conforms to **data**.
- **plist date** — ISO-8601 date, conforms to **date**, unsupported.
- **plist boolean** — logical state object, which is either true (1) or false (0), conforms to **true** and **false**.
- **plist integer** — possibly signed integer number in base 10, conforms to **integer**. Fits in 64-bit unsigned integer in two's complement representation, unless a smaller signed or unsigned integral type is explicitly mentioned in specific **plist object** description.
- **plist real** — floating point number, conforms to **real**, unsupported.
- **plist metadata** — value cast to data by the implementation. Permits passing **plist string**, in which case the result is represented by a null-terminated sequence of bytes (aka C string), **plist integer**, in which case the result is represented by *32-bit* little endian sequence of bytes in two's complement representation, **plist boolean**, in which case the value is one byte: 01 for **true** and 00 for **false**, and **plist data** itself. All other types or larger integers invoke undefined behaviour.

## 3 Overview

### 3.1 Configuration Terms

- **OC config** — OpenCore Configuration file in **plist** format named **config.plist**. It has to provide extensible way to configure OpenCore and is structured to be separated into multiple named sections situated in the root **plist** dictionary. These sections are permitted to have **plist array** or **plist dictionary** types and are described in corresponding sections of this document.
- **valid key** — **plist key** object of **OC config** described in this document or its future revisions. Besides explicitly described **valid keys**, keys starting with **#** symbol (e.g. **#Hello**) are also considered **valid keys** and behave as comments, effectively discarding their value, which is still required to be a **valid plist object**. All other **plist keys** are not valid, and their presence yields to **undefined behaviour**.
- **valid value** — **valid plist object** of **OC config** described in this document that matches all the additional requirements in specific **plist object** description if any.
- **invalid value** — **valid plist object** of **OC config** described in this document that is of other **plist type**, does not conform to additional requirements found in specific **plist object** description (e.g. value range), or missing from the corresponding collection. **Invalid value** is read with or without an error message as any possible value of this **plist object** in an undetermined manner (i.e. the values may not be same across the reboots). Whilst reading an **invalid value** is equivalent to reading certain defined **valid value**, applying incompatible value to the host system may yield to **undefined behaviour**.
- **optional value** — **valid value** of **OC config** described in this document that reads in a certain defined manner provided in specific **plist object** description (instead of **invalid value**) when not present in **OC config**. All other cases of **invalid value** do still apply. Unless explicitly marked as **optional value**, any other value is required to be present and reads to **invalid value** if missing.
- **fatal behaviour** — behaviour leading to boot termination. Implementation must stop the boot process from going any further until next host system boot. It is allowed but not required to perform cold reboot or show any warning message.
- **undefined behaviour** — behaviour not prescribed by this document. Implementation is allowed to take any measures including but not limited to **fatal behaviour**, assuming any states or values, or ignoring, unless these measures negatively affect system security in general.

### 3.2 Configuration Processing

**OC config** is guaranteed to be processed at least once if it was found. Depending on OpenCore bootstrapping mechanism multiple **OC config** files may lead to reading any of them. No **OC Config** may be present on disk, in which case all the values read follow the rules of **invalid value** and **optional value**.

**OC config** has size, nesting, and key amount limitations. **OC config** size does not exceed 16 MBs. **OC config** has no more than 8 nesting levels. **OC config** has up to 16384 XML nodes (i.e. one **plist dictionary** item is counted as a pair of nodes) within each **plist object**.

Reading malformed **OC config** file leads to **undefined behaviour**. Examples of malformed **OC config** cover at least the following cases:

- files non-conformant to **plist** DTD
- files with unsupported or non-conformant **plist objects** found in this document
- files violating size, nesting, and key amount limitations

It is recommended but not required to abort loading malformed **OC config** and continue as if no **OC config** was present. For forward compatibility it is recommended but not required for the implementation to warn about the use of **invalid values**. Recommended practice of interpreting **invalid values** is to conform to the following convention where applicable:

Type	Value
<b>plist string</b>	Empty string ( <code>&lt;string&gt;&lt;/string&gt;</code> )
<b>plist data</b>	Empty data ( <code>&lt;data&gt;&lt;/data&gt;</code> )

Type	Value
<code>plist integer</code>	0 (<integer>0</integer>)
<code>plist boolean</code>	False (<false/>)
<code>plist tristate</code>	False (<false/>)

### 3.3 Configuration Structure

OC `config` is separated into following sections, which are described in separate sections of this document. By default it is tried to not enable anything and optionally provide kill switches with `Enable` property for `plist dict` entries. In general the configuration is written idiomatically to group similar actions in subsections:

- `Add` provides support for data addition.
- `Block` provides support for data removal or ignorance.
- `Patch` provides support for data modification.
- `Quirks` provides support for specific hacks.

Root configuration entries consist of the following:

- `ACPI`
- `DeviceProperties`
- `Kernel`
- `Misc`
- `NVRAM`
- `PlatformInfo`
- `UEFI`

*Note:* Currently most properties try to have defined values even if not specified in the configuration for safety reasons. This behaviour should not be relied upon, and all fields must be properly specified in the configuration.

### 3.4 Directory Structure

When directory boot is used the directory structure used should follow the description on Directory Structure figure. Available entries include:

- `BOOTx64.efi`  
Initial booter, which loads `OpenCore.efi` unless it was already started as a driver.
- `ACPI`  
Directory used for storing supplemental ACPI information for `ACPI` section.
- `Drivers`  
Directory used for storing supplemental UEFI drivers for `UEFI` section.
- `Kexts`  
Directory used for storing supplemental kernel information for `Kernel` section.
- `OpenCore.efi`  
Main booter driver responsible for operating system loading.
- `vault.plist`  
Hashes for all files potentially loadable by OC `Config`.
- `config.plist`  
OC `Config`.
- `vault.sig`  
Signature for `vault.plist`.

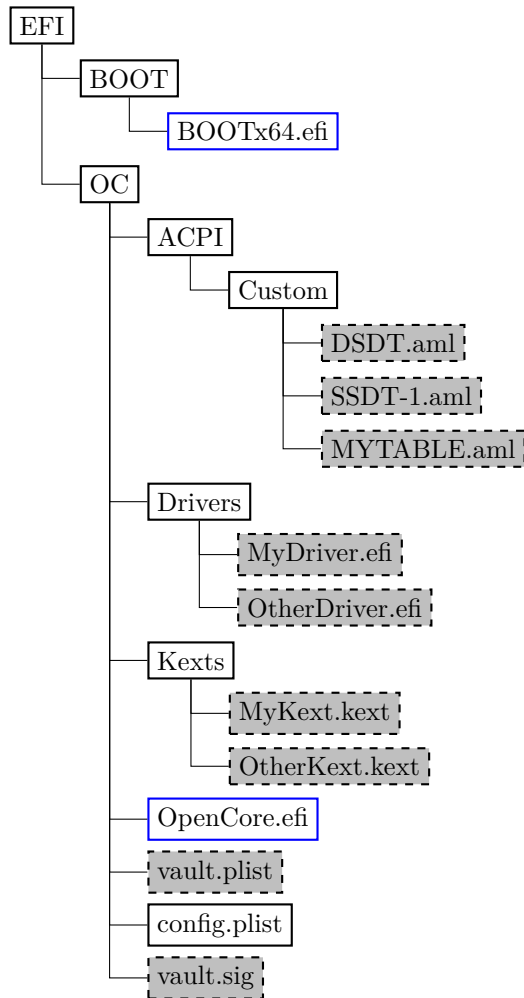

Figure 1. Directory Structure

### 3.5 Contribution

OpenCore can be compiled as an ordinary EDK II package with UDK 2018.

The only officially supported toolchain is XCODE5. Other toolchains might work, but are neither supported, nor recommended. Contribution of clean patches is welcome. Please do follow EDK II C Codestyle.

Required external package dependencies include EfiPkg, MacInfoPkg, and OcSupportPkg.

To compile with XCODE5, besides Xcode, one should also install NASM and MTOC. Example command sequence may look as follows:

---

```

git clone https://github.com/tianocore/edk2 -b UDK2018 UDK
cd UDK
git clone https://github.com/acidanthera/EfiPkg
git clone https://github.com/acidanthera/MacInfoPkg
git clone https://github.com/acidanthera/OcSupportPkg
git clone https://github.com/acidanthera/OpenCorePkg
source edksetup.sh
make -C BaseTools
build -a X64 -b RELEASE -t XCODE5 -p OpenCorePkg/OpenCorePkg.dsc
  
```

---

Listing 1: Compilation Commands



NOOPT or DEBUG build modes instead of RELEASE can produce a lot more debug output. With NOOPT source level debugging with GDB or IDA Pro is also available. For GDB check OcSupport Debug page. For IDA Pro you will need IDA Pro 7.3 or newer.

For IDE usage Xcode projects are available in the root of the repositories. Another approach could be Sublime Text with EasyClangComplete plugin. Add .clang\_complete file with similar content to your UDK root:

---

```
-I/UefiPackages/MdePkg
-I/UefiPackages/MdePkg/Include
-I/UefiPackages/MdePkg/Include/X64
-I/UefiPackages/EfiPkg
-I/UefiPackages/EfiPkg/Include
-I/UefiPackages/EfiPkg/Include/X64
-I/UefiPackages/AptioFixPkg/Include
-I/UefiPackages/AppleSupportPkg/Include
-I/UefiPackages/OpenCorePkg/Include
-I/UefiPackages/OcSupportPkg/Include
-I/UefiPackages/IntelFrameworkPkg/Include
-I/UefiPackages/MacInfoPkg/Include
-IInclude
-include
/UefiPackages/MdePkg/Include/Uefi.h
-fshort-wchar
-Wall
-Wextra
-Wno-unused-parameter
-Wno-missing-braces
-Wno-missing-field-initializers
-Wno-tautological-compare
-Wno-sign-compare
-Wno-varargs
-Wno-unused-const-variable
```

---

Listing 2: ECC Configuration

## 4 ACPI

### 4.1 Introduction

ACPI (Advanced Configuration and Power Interface) is an open standard to discover and configure computer hardware. ACPI specification defines the standard tables (e.g. DSDT, SSDT, FACS, DMAR) and various methods (e.g. \_DSM, \_PWR) for implementation. Modern hardware needs little changes to maintain ACPI compatibility, yet some of those are provided as a part of OpenCore.

### 4.2 Properties

1. Add

**Type:** plist array

**Default value:** Empty

**Description:** Load selected tables from OC/ACPI/Custom directory.

Designed to be filled with `plist dict` values, describing each block entry. See Add Properties section below.

2. Block

**Type:** plist array

**Default value:** Empty

**Description:** Remove selected tables from ACPI stack.

Designed to be filled with `plist dict` values, describing each block entry. See Block Properties section below.

3. Patch

**Type:** plist array

**Default value:** Empty

**Description:** Perform binary patches in ACPI tables before table addition or removal.

Designed to be filled with `plist dictionary` values describing each patch entry. See Patch Properties section below.

4. Quirks

**Type:** plist dict

**Description:** Apply individual ACPI quirks described in Quirks Properties section below.

### 4.3 Add Properties

1. Comment

**Type:** plist string

**Default value:** Empty string

**Description:** Arbitrary ASCII string used to provide human readable reference for the entry. It is implementation defined whether this value is used.

2. Enabled

**Type:** plist boolean

**Default value:** false

**Description:** This ACPI table will not be added unless set to `true`.

3. Path

**Type:** plist string

**Default value:** Empty string

**Description:** File paths meant to be loaded as ACPI tables. Example values include `DSDT.aml`, `SubDir/SSDT-8.aml`, `SSDT-USBX.aml`, etc.

ACPI table load order follows the item order in the array. All ACPI tables load from OC/ACPI/Custom directory.

**Note:** All tables but tables with DSDT table identifier (determined by parsing data not by filename) insert new tables into ACPI stack. DSDT, unlike the rest, performs replacement of DSDT table.

## 4.4 Block Properties

1. All  
**Type:** plist boolean  
**Default value:** false  
**Description:** If set to `true`, all ACPI tables matching the condition will be dropped. Otherwise only first matched table.
2. Comment  
**Type:** plist string  
**Default value:** Empty string  
**Description:** Arbitrary ASCII string used to provide human readable reference for the entry. It is implementation defined whether this value is used.
3. Enabled  
**Type:** plist boolean  
**Default value:** false  
**Description:** This ACPI table will not be removed unless set to `true`.
4. OemTableId  
**Type:** plist data, 8 bytes  
**Default value:** All zero  
**Description:** Match table OEM ID to be equal to this value unless all zero.
5. TableLength  
**Type:** plist integer  
**Default value:** 0  
**Description:** Match table size to be equal to this value unless 0.
6. TableSignature  
**Type:** plist data, 4 bytes  
**Default value:** All zero  
**Description:** Match table signature to be equal to this value unless all zero.

## 4.5 Patch Properties

1. Comment  
**Type:** plist string  
**Default value:** Empty string  
**Description:** Arbitrary ASCII string used to provide human readable reference for the entry. It is implementation defined whether this value is used.
2. Count  
**Type:** plist integer  
**Default value:** 0  
**Description:** Number of patch occurrences to apply. 0 applies the patch to all occurrences found.
3. Enabled  
**Type:** plist boolean  
**Default value:** false  
**Description:** This ACPI patch will not be used unless set to `true`.
4. Find  
**Type:** plist data  
**Default value:** Empty data  
**Description:** Data to find. Must equal to `Replace` in size.
5. Limit  
**Type:** plist integer  
**Default value:** 0  
**Description:** Maximum number of bytes to search for. Can be set to 0 to look through the whole ACPI table.

6. **Mask**  
**Type:** plist data  
**Default value:** Empty data  
**Description:** Data bitwise mask used during find comparison. Allows fuzzy search by ignoring not masked (set to zero) bits. Can be set to empty data to be ignored. Must equal to **Replace** in size otherwise.
7. **OemTableId**  
**Type:** plist data, 8 bytes  
**Default value:** All zero  
**Description:** Match table OEM ID to be equal to this value unless all zero.
8. **Replace**  
**Type:** plist data  
**Default value:** Empty data  
**Description:** Replacement data of one or more bytes.
9. **ReplaceMask**  
**Type:** plist data  
**Default value:** Empty data  
**Description:** Data bitwise mask used during replacement. Allows fuzzy replacement by updating masked (set to non-zero) bits. Can be set to empty data to be ignored. Must equal to **Replace** in size otherwise.
10. **Skip**  
**Type:** plist integer  
**Default value:** 0  
**Description:** Number of found occurrences to be skipped before replacement is done.
11. **TableLength**  
**Type:** plist integer  
**Default value:** 0  
**Description:** Match table size to be equal to this value unless 0.
12. **TableSignature**  
**Type:**  
textttplist data, 4 bytes  
**Default value:** All zero  
**Description:** Match table signature to be equal to this value unless all zero.

In the majority of the cases ACPI patches are not useful and harmful:

- Avoid renaming devices with ACPI patches. This may fail or perform improper renaming of unrelated devices (e.g. EC and ECO), be unnecessary, or even fail to rename devices in select tables. For ACPI consistency it is much safer to rename devices at I/O Registry level, as done by WhateverGreen.
- Avoid patching `_OSI` to support a higher level of feature sets unless absolutely required. Commonly this enables a number of hacks on APTIO firmwares, which result in the need to add more patches. Modern firmwares generally do not need it at all, and those that do are fine with much smaller patches.
- Try to avoid hacky changes like renaming `_PWR` or `_DSM` whenever possible.

Several cases, where patching actually does make sense, include:

- Refreshing HPET (or another device) method header to avoid compatibility checks by `_OSI` on legacy hardware. `_STA` method with `if ((OSFL () == Zero)) { If (HPTE) ... Return (Zero)` content may be forced to always return 0xF by replacing `A0 10 93 4F 53 46 4C 00` with `A4 0A 0F A3 A3 A3 A3`.
- To provide custom method implementation with in an SSDT, for instance, to report functional key presses on a laptop, the original method can be replaced with a dummy name by patching `_Q11` with `XQ11`.

Tianocore AcpiAml.h source file may help understanding ACPI opcodes.

## 4.6 Quirks Properties

1. **FadtEnableReset**  
**Type:** plist boolean

**Default value:** false

**Description:** Provide reset register and flag in FADT table to enable reboot and shutdown on legacy hardware. Not recommended unless required.

2. `IgnoreForWindows`

**Type:** plist boolean

**Default value:** false

**Description:** Disable all sorts of ACPI modifications when booting Windows operating system.

This flag implements a quick workaround for those, who made their ACPI tables incompatible with Windows, but need it right now. Not recommended, as ACPI tables must be compatible with any operating system regardless of the changes.

*Note:* This option may be removed in the future.

3. `NormalizeHeaders`

**Type:** plist boolean

**Default value:** false

**Description:** Cleanup ACPI header fields to workaround macOS ACPI implementation bug causing boot crashes. Reference: Debugging AppleACPIPlatform on 10.13 by Alex James aka theracermaster. The issue is fixed in macOS Mojave (10.14).

4. `RebaseRegions`

**Type:** plist boolean

**Default value:** false

**Description:** Attempt to heuristically relocate ACPI memory regions. Not recommended.

ACPI tables are often generated dynamically by underlying firmware implementation. Among the position-independent code, ACPI tables may contain physical addresses of MMIO areas used for device configuration, usually grouped in regions (e.g. `OperationRegion`). Changing firmware settings or hardware configuration, upgrading or patching the firmware inevitably leads to changes in dynamically generated ACPI code, which sometimes lead to the shift of the addresses in aforementioned `OperationRegion` constructions.

For this reason it is very dangerous to apply any kind of modifications to ACPI tables. The most reasonable approach is to make as few as possible changes to ACPI and try to not replace any tables, especially DSDT. When this is not possible, then at least attempt to ensure that custom DSDT is based on the most recent DSDT or remove writes and reads for the affected areas.

When nothing else helps this option could be tried to avoid stalls at `PCI Configuration Begin` phase of macOS booting by attempting to fix the ACPI addresses. It does not do magic, and only works with most common cases. Do not use unless absolutely required.

## 5 DeviceProperties

### 5.1 Introduction

Device configuration is provided to macOS with a dedicated buffer, called `EfiDevicePropertyDatabase`. This buffer is a serialised map of `DevicePaths` to a map of property names and their values.

Property data can be debugged with `gfxutil`. To obtain current property data use the following command in macOS:

---

```
ioreg -lw0 -p IODeviceTree -n efi -r -x | grep device-properties |  
sed 's/.*<\/;s/>.*//' > /tmp/device-properties.hex &&  
gfxutil /tmp/device-properties.hex /tmp/device-properties.plist &&  
cat /tmp/device-properties.plist
```

---

### 5.2 Properties

1. Add

**Type:** `plist dict`

**Description:** Sets device properties from a map (`plist dict`) of device paths to a map (`plist dict`) of variable names and their values in `plist metadata` format. Device paths must be provided in canonic string format (e.g. `PciRoot(0x0)/Pci(0x1,0x0)/Pci(0x0,0x0)`). Properties will only be set if not present and not blocked.

*Note:* Currently properties may only be (formerly) added by the original driver, so unless a separate driver was installed, there is no reason to block the variables.

2. Block

**Type:** `plist dict`

**Description:** Removes device properties from a map (`plist dict`) of device paths to an array (`plist array`) of variable names in `plist string` format.

### 5.3 Common Properties

Some known properties include:

- `device-id`  
User-specified device identifier used for I/O Kit matching. Has 4 byte data type.
- `vendor-id`  
User-specified vendor identifier used for I/O Kit matching. Has 4 byte data type.
- `AAPL,ig-platform-id`  
Intel GPU framebuffer identifier used for framebuffer selection on Ivy Bridge and newer. Has 4 byte data type.
- `AAPL,snb-platform-id`  
Intel GPU framebuffer identifier used for framebuffer selection on Sandy Bridge. Has 4 byte data type.
- `layout-id`  
Audio layout used for AppleHDA layout selection. Has 4 byte data type.

## 6 Kernel

### 6.1 Introduction

This section allows to apply different kinds of kernelspace modifications on Apple Kernel (XNU). The modifications currently provide driver (kext) injection, kernel and driver patching, and driver blocking.

### 6.2 Properties

1. Add

**Type:** plist array

**Default value:** Empty

**Description:** Load selected kernel drivers from `OC/Kexts` directory.

Designed to be filled with `plist dict` values, describing each driver. See Add Properties section below. Kernel driver load order follows the item order in the array, thus the dependencies should be written prior to their consumers.

2. Block

**Type:** plist array

**Default value:** Empty

**Description:** Remove selected kernel drivers from prelinked kernel.

Designed to be filled with `plist dictionary` values, describing each blocked driver. See Block Properties section below.

3. Patch

**Type:** plist array

**Default value:** Empty

**Description:** Perform binary patches in kernel and drivers prior to driver addition and removal.

Designed to be filled with `plist dictionary` values, describing each patch. See Patch Properties section below.

4. Quirks

**Type:** plist dict

**Description:** Apply individual kernel and driver quirks described in Quirks Properties section below.

### 6.3 Add Properties

1. BundlePath

**Type:** plist string

**Default value:** Empty string

**Description:** Kext bundle path (e.g. `Lilu.kext` or `MyKext.kext/Contents/PlugIns/MySubKext.kext`).

2. Comment

**Type:** plist string

**Default value:** Empty string

**Description:** Arbitrary ASCII string used to provide human readable reference for the entry. It is implementation defined whether this value is used.

3. Enabled

**Type:** plist boolean

**Default value:** false

**Description:** This kernel driver will not be added unless set to `true`.

4. ExecutablePath

**Type:** plist string

**Default value:** Empty string

**Description:** Kext executable path relative to bundle (e.g. `Contents/MacOS/Lilu`).

5. MatchKernel

**Type:** plist string

**Default value:** Empty string

**Description:** Blocks kernel driver on selected macOS version only. The selection happens based on prefix match with the kernel version, i.e. 16.7.0 will match macOS 10.12.6 and 16. will match any macOS 10.12.x version.

#### 6. PlistPath

**Type:** plist string

**Default value:** Empty string

**Description:** Kext Info.plist path relative to bundle (e.g. Contents/Info.plist).

### 6.4 Block Properties

#### 1. Comment

**Type:** plist string

**Default value:** Empty string

**Description:** Arbitrary ASCII string used to provide human readable reference for the entry. It is implementation defined whether this value is used.

#### 2. Enabled

**Type:** plist boolean

**Default value:** false

**Description:** This kernel driver will not be blocked unless set to true.

#### 3. Identifier

**Type:** plist string

**Default value:** Empty string

**Description:** Kext bundle identifier (e.g. com.apple.driver.AppleTyMCEDriver).

#### 4. MatchKernel

**Type:** plist string

**Default value:** Empty string

**Description:** Blocks kernel driver on selected macOS version only. The selection happens based on prefix match with the kernel version, i.e. 16.7.0 will match macOS 10.12.6 and 16. will match any macOS 10.12.x version.

### 6.5 Patch Properties

#### 1. Base

**Type:** plist string

**Default value:** Empty string

**Description:** Selects symbol-matched base for patch lookup (or immediate replacement) by obtaining the address of provided symbol name. Can be set to empty string to be ignored.

#### 2. Comment

**Type:** plist string

**Default value:** Empty string

**Description:** Arbitrary ASCII string used to provide human readable reference for the entry. It is implementation defined whether this value is used.

#### 3. Count

**Type:** plist integer

**Default value:** 0

**Description:** Number of patch occurrences to apply. 0 applies the patch to all occurrences found.

#### 4. Enabled

**Type:** plist boolean

**Default value:** false

**Description:** This kernel patch will not be used unless set to true.

#### 5. Find

**Type:** plist data

**Default value:** Empty data

**Description:** Data to find. Can be set to empty for immediate replacement at Base. Must equal to Replace in size otherwise.



6. Identifier
  - Type:** plist string
  - Default value:** Empty string
  - Description:** Kext bundle identifier (e.g. `com.apple.driver.AppleHDA`) or `kernel` for kernel patch.
7. Limit
  - Type:** plist integer
  - Default value:** 0
  - Description:** Maximum number of bytes to search for. Can be set to 0 to look through the whole kext or kernel.
8. Mask
  - Type:** plist data
  - Default value:** Empty data
  - Description:** Data bitwise mask used during find comparison. Allows fuzzy search by ignoring not masked (set to zero) bits. Can be set to empty data to be ignored. Must equal to **Replace** in size otherwise.
9. MatchKernel
  - Type:** plist string
  - Default value:** Empty string
  - Description:** Adds kernel driver to selected macOS version only. The selection happens based on prefix match with the kernel version, i.e. `16.7.0` will match macOS 10.12.6 and `16.` will match any macOS 10.12.x version.
10. Replace
  - Type:** plist data
  - Default value:** Empty data
  - Description:** Replacement data of one or more bytes.
11. ReplaceMask
  - Type:** plist data
  - Default value:** Empty data
  - Description:** Data bitwise mask used during replacement. Allows fuzzy replacement by updating masked (set to non-zero) bits. Can be set to empty data to be ignored. Must equal to **Replace** in size otherwise.
12. Skip
  - Type:** plist integer
  - Default value:** 0
  - Description:** Number of found occurrences to be skipped before replacement is done.

## 6.6 Quirks Properties

1. AppleCpuPmCfgLock
  - Type:** plist boolean
  - Default value:** false
  - Description:** Disables `PKG_CST_CONFIG_CONTROL (0xE2)` MSR modification in `AppleIntelCPUPowerManagement.kext`, commonly causing early kernel panic, when it is locked from writing.
  - Note:* This option should avoided whenever possible. Modern firmwares provide **CFG Lock** setting, disabling which is much cleaner. More details about the issue can be found in `VerifyMsrE2` notes.
2. AppleXcpmCfgLock
  - Type:** plist boolean
  - Default value:** false
  - Description:** Disables `PKG_CST_CONFIG_CONTROL (0xE2)` MSR modification in XNU kernel, commonly causing early kernel panic, when it is locked from writing (XCPM power management).
  - Note:* This option should avoided whenever possible. Modern firmwares provide **CFG Lock** setting, disabling which is much cleaner. More details about the issue can be found in `VerifyMsrE2` notes.
3. ExternalDiskIcons
  - Type:** plist boolean
  - Default value:** false
  - Description:** Apply icon type patches to `IOAHCIPort.kext` to force internal disk icons for all AHCI disks.

*Note:* This option should avoided whenever possible. Modern firmwares usually have compatible AHCI controllers.

#### 4. ThirdPartyTrim

**Type:** plist boolean

**Default value:** false

**Description:** Patch IOAHCIFamily.kext to force TRIM command support on AHCI SSDs.

*Note:* This option should avoided whenever possible. NVMe SSDs are compatible without the change. For AHCI SSDs on modern macOS version there is a dedicated built-in utility called `trimforce`.

#### 5. XhciPortLimit

**Type:** plist boolean

**Default value:** false

**Description:** Patch various kexts (AppleUSBXHCI.kext, AppleUSBXHCIPCI.kext, IOUSBHostFamily.kext) to remove USB port count limit of 15 ports.

*Note:* This option should avoided whenever possible. USB port limit is imposed by the amount of used bits in locationID format and there is no possible way to workaround this without heavy OS modification. The only valid solution is to limit the amount of used ports to 15 (discarding some). More details can be found on [AppleLife.ru](http://AppleLife.ru).

## 7 Misc

### 7.1 Introduction

This section contains miscellaneous configuration entries for OpenCore behaviour that does not go to any other sections

### 7.2 Properties

1. **Boot**  
**Type:** plist dict  
**Description:** Apply boot configuration described in Boot Properties section below.
2. **Debug**  
**Type:** plist dict  
**Description:** Apply debug configuration described in Debug Properties section below.
3. **Security**  
**Type:** plist dict  
**Description:** Apply security configuration described in Security Properties section below.

### 7.3 Boot Properties

1. **ConsoleMode**  
**Type:** plist string  
**Default value:** Empty string  
**Description:** Sets console output mode as specified with the WxH (e.g. 80x24) formatted string. Set to empty string not to change console mode. Set to **Max** to try to use largest available console mode.
2. **ConsoleBehaviourOs**  
**Type:** plist string  
**Default value:** Empty string  
**Description:** Set console control behaviour upon operating system load.

Console control is a legacy protocol used for switching between text and graphics screen output. Some firmwares do not provide it, yet select operating systems require its presence, which is what **ProvideConsoleControl** UEFI quirk is for.

When console control is available, OpenCore can be made console control aware, and and set different modes for the operating system booter (**ConsoleBehaviourOs**), which normally runs in graphics mode, and its own user interface (**ConsoleBehaviourUi**), which normally runs in text mode. Possible behaviours, set as values of these options, include:

- Empty string — Do not modify console control mode.
- **Text** — Switch to text mode.
- **Graphics** — Switch to graphics mode.
- **ForceText** — Switch to text mode and preserve it (requires **ProvideConsoleControl**).
- **ForceGraphics** — Switch to graphics mode and preserve it (require **ProvideConsoleControl**).

Hints:

- Unless empty works, firstly try to set **ConsoleBehaviourOs** to **Graphics** and **ConsoleBehaviourUi** to **Text**.
- On APTIO IV (Haswell and earlier) it is usually enough to have **ConsoleBehaviourOs** set to **Graphics** and **ConsoleBehaviourUi** set to **ForceText** to avoid visual glitches.
- On APTIO V (Broadwell and newer) **ConsoleBehaviourOs** set to **ForceGraphics** and **ConsoleBehaviourUi** set to **Text** usually works best.

*Note:* **IgnoreTextInGraphics** may need to be enabled for select firmware implementations.

3. **ConsoleBehaviourUi**  
**Type:** plist string  
**Default value:** Empty string  
**Description:** Set console control behaviour upon OpenCore user interface load. Refer to **ConsoleBehaviourOs** description for details.

4. HideSelf
 

**Type:** plist boolean  
**Default value:** false  
**Description:** Hides own boot entry from boot picker. This may potentially hide other entries, for instance, when another UEFI OS is installed on the same volume and driver boot is used.
5. Resolution
 

**Type:** plist string  
**Default value:** Empty string  
**Description:** Sets console output screen resolution as specified with the WxH@Bpp (e.g. 1920x1080@32) or WxH (e.g. 1920x1080) formatted string. Set to empty string not to change screen resolution. Set to Max to try to use largest available screen resolution.

*Note:* This will fail when console handle has no GOP protocol. When the firmware does not provide it, it can be added with ProvideConsoleGop UEFI quirk set to true.
6. ShowPicker
 

**Type:** plist boolean  
**Default value:** false  
**Description:** Show simple boot picker to allow boot entry selection.
7. Timeout
 

**Type:** plist integer, 32 bit  
**Default value:** 0  
**Description:** Timeout in seconds in boot picker before automatic booting of the default boot entry.

## 7.4 Debug Properties

1. DisableWatchDog
 

**Type:** plist boolean  
**Default value:** NO  
**Description:** Select firmwares may not succeed in quickly booting the operating system, especially in debug mode, which results in watch dog timer aborting the process. This option turns off watch dog timer.
2. DisplayDelay
 

**Type:** plist integer  
**Default value:** 0  
**Description:** Delay in microseconds performed after every printed line visible onscreen (i.e. console).
3. DisplayLevel
 

**Type:** plist integer, 64 bit  
**Default value:** 0  
**Description:** EDK II debug level bitmask (sum) showed onscreen. Unless **Target** enables console (onscreen) printing, onscreen debug output will not be visible. The following levels are supported (discover more in DebugLib.h):

  - 0x00000002 — DEBUG\_WARN in DEBUG, NOOPT, RELEASE.
  - 0x00000040 — DEBUG\_INFO in DEBUG, NOOPT.
  - 0x00400000 — DEBUG\_VERBOSE in custom builds.
  - 0x80000000 — DEBUG\_ERROR in DEBUG, NOOPT, RELEASE.
4. ExposeBootPath
 

**Type:** plist boolean  
**Default value:** false  
**Description:** Expose printable booter path to OpenCore.efi or its booter (depending on the load order) as an UEFI variable.

To obtain booter path use the following command in macOS:

---

```
nvram 4D1FDA02-38C7-4A6A-9CC6-4BCCA8B30102:boot-path
```

---

To use booter path for mounting booter volume use the following command in macOS:

---

```
u=$(nvram 4D1FDA02-38C7-4A6A-9CC6-4BCCA8B30102:boot-path | sed 's/*GPT,\([^;]*\),*/\1/'); \
if [ "$u" != "" ]; then sudo diskutil mount $u ; fi
```

---

## 5. Target

**Type:** plist integer

**Default value:** 0

**Description:** A bitmask (sum) of enabled logging targets. By default all the logging output is hidden, so this option is required to be set when debugging is necessary.

The following logging targets are supported:

- 0x01 — Enable logging, otherwise all log is discarded.
- 0x02 — Enable basic console (onscreen) logging.
- 0x04 — Enable logging to Data Hub.
- 0x08 — Enable serial port logging.
- 0x10 — Enable UEFI variable logging.
- 0x20 — Enable non-volatile UEFI variable logging.
- 0x40 — Enable logging to file.

Console logging prints less than all the other variants. Depending on the build type (RELEASE, DEBUG, or NOOPT) different amount of logging may be read (from least to most).

Data Hub log will not log kernel and kext patches. To obtain Data Hub log use the following command in macOS:

---

```
ioreg -lw0 -p IODeviceTree | grep boot-log | sort | sed 's/*<(.*)>*/\1/' | xxd -r -p
```

---

UEFI variable log does not include some messages and has no performance data. For safety reasons log size is limited to 32 kilobytes. Some firmwares may truncate it much earlier or drop completely if they have no memory. Using non-volatile flag will write the log to NVRAM flash after every printed line. To obtain UEFI variable log use the following command in macOS:

---

```
nvram 4D1FDA02-38C7-4A6A-9CC6-4BCCA8B30102:boot-log | \
awk '{gsub(/%0d%0a%00/, "");gsub(/%0d%0a/, "\n")}'1'
```

---

While OpenCore boot log already contains basic version information with build type and date, this data may also be found in NVRAM in `opencore-version` variable even with boot log disabled:

---

```
nvram 4D1FDA02-38C7-4A6A-9CC6-4BCCA8B30102:opencore-version
```

---

File logging will create a file named `opencore.log` at EFI volume root with log contents. Please be warned that some file system drivers present in firmwares are not reliable, and may corrupt data when writing files through UEFI. Log is attempted to be written in the safest manner, and thus is very slow. Ensure that `DisableWatchDog` is set to `true` when you use a slow drive.

## 7.5 Security Properties

### 1. HaltLevel

**Type:** plist integer, 64 bit

**Default value:** 0x80000000 (DEBUG\_ERROR)

**Description:** EDK II debug level bitmask (sum) causing CPU to halt (stop execution) after obtaining a message of `HaltLevel`. Possible values match `DisplayLevel` values.

### 2. RequireSignature

**Type:** plist boolean

**Default value:** true

**Description:** Require `vault.sig` signature file for `vault.plist` in OC directory.

This file should contain a raw 256 byte RSA-2048 signature from SHA-256 hash of `vault.plist`. The signature is verified against the public key embedded into `OpenCore.efi`.

To embed the public key you should do either of the following:

- Provide public key during the `OpenCore.efi` compilation in `OpenCoreVault.c` file.
- Binary patch `OpenCore.efi` replacing zeroes with the public key between `=BEGIN OC VAULT=` and `==END OC VAULT==` ASCII markers.

RSA public key 520 byte format description can be found in Chromium OS documentation. To convert public key from X.509 certificate or from PEM file use `RsaTool`.

*Note:* `vault.sig` is used regardless of this option when public key is embedded into `OpenCore.efi`. Setting it to `true` will only ensure configuration sanity, and abort the boot process when public key is not set but was supposed to be used for verification.

### 3. `RequireVault`

**Type:** `plist boolean`

**Default value:** `true`

**Description:** Require `vault.plist` file present in `OC` directory.

This file should contain SHA-256 hashes for all files used by `OpenCore`. Presence of this file is highly recommended to ensure that unintentional file modifications (including filesystem corruption) do not happen unnoticed. To create this file automatically use `create_vault.sh` script.

Regardless of the underlying filesystem, path name and case must match between `config.plist` and `vault.plist`.

*Note:* `vault.plist` is tried to be read regardless of the value of this option, but setting it to `true` will ensure configuration sanity, and abort the boot process.

The complete set of commands to:

- Create `vault.plist`.
- Create a new RSA key (always do this to avoid loading old configuration).
- Embed RSA key into `OpenCore.efi`.
- Create `vault.sig`.

Can look as follows:

---

```
cd /Volumes/EFI/EFI/OC
/path/to/create_vault.sh .
/path/to/RsaTool -sign vault.plist vault.sig vault.pub
off=$((($(strings -a -t d OpenCore.efi | grep "=BEGIN OC VAULT=" | cut -f1 -d' ')+16))
dd of=OpenCore.efi if=vault.pub bs=1 seek=$off count=520 conv=notrunc
rm vault.pub
```

---

*Note:* While it may appear obvious, but you have to use an external method to verify `OpenCore.efi` and `BOOTx64.efi` for secure boot path. For this you are recommended to at least enable UEFI SecureBoot with a custom certificate, and sign `OpenCore.efi` and `BOOTx64.efi` with your custom key. More details on customising secure boot on modern firmwares can be found in Taming UEFI SecureBoot paper (in Russian).

## 8 NVRAM

### 8.1 Introduction

Has `plist dict` type and allows to set volatile UEFI variables commonly referred as NVRAM variables. Refer to `man nvram` for more details. macOS extensively uses NVRAM variables for OS — Bootloader — Firmware intercommunication, and thus supplying several NVRAM is required for proper macOS functioning.

Each NVRAM variable consists of its name, value, attributes (refer to UEFI specification), and its GUID, representing which ‘section’ NVRAM variable belongs to. macOS uses several GUIDs, including but not limited to:

- 4D1EDE05-38C7-4A6A-9CC6-4BCCA8B38C14 (APPLE\_VENDOR\_VARIABLE\_GUID)
- 7C436110-AB2A-4BBB-A880-FE41995C9F82 (APPLE\_BOOT\_VARIABLE\_GUID)
- 8BE4DF61-93CA-11D2-AA0D-00E098032B8C (EFI\_GLOBAL\_VARIABLE\_GUID)
- 4D1FDA02-38C7-4A6A-9CC6-4BCCA8B30102 (OC\_VENDOR\_VARIABLE\_GUID)

*Note:* Some of the variables may be added by PlatformNVRAM or Generic subsections of PlatformInfo section. Please ensure that variables of this section never collide with them, as behaviour is undefined otherwise.

### 8.2 Properties

#### 1. Add

**Type:** `plist dict`

**Description:** Sets NVRAM variables from a map (`plist dict`) of GUIDs to a map (`plist dict`) of variable names and their values in `plist metadata` format. GUIDs must be provided in canonic string format in upper or lower case (e.g. 8BE4DF61-93CA-11D2-AA0D-00E098032B8C).

Created variables get `EFI_VARIABLE_BOOTSERVICE_ACCESS` and `EFI_VARIABLE_RUNTIME_ACCESS` attributes set. Variables will only be set if not present and not blocked. To overwrite a variable add it to `Block` section. This approach enables to provide default values till the operating system takes the lead.

*Note:* If `plist` key does not conform to GUID format, behaviour is undefined.

#### 2. Block

**Type:** `plist dict`

**Description:** Removes NVRAM variables from a map (`plist dict`) of GUIDs to an array (`plist array`) of variable names in `plist string` format.

To read NVRAM variable value from macOS one could use `nvram` by concatenating variable GUID and name separated by `:` symbol. For example, `nvram 7C436110-AB2A-4BBB-A880-FE41995C9F82:boot-args`.

A continuously updated variable list can be found in a corresponding document: NVRAM Variables.

### 8.3 Mandatory Variables

*Warning:* These variables may be added by PlatformNVRAM or Generic subsections of PlatformInfo section. Using `PlatformInfo` is the recommend way of setting these variables.

The following variables are mandatory for macOS functioning:

- 4D1EDE05-38C7-4A6A-9CC6-4BCCA8B38C14:FirmwareFeatures  
32-bit `FirmwareFeatures`. Present on all Macs to avoid extra parsing of SMBIOS tables
- 4D1EDE05-38C7-4A6A-9CC6-4BCCA8B38C14:FirmwareFeaturesMask  
32-bit `FirmwareFeaturesMask`. Present on all Macs to avoid extra parsing of SMBIOS tables.
- 4D1EDE05-38C7-4A6A-9CC6-4BCCA8B38C14:MLB  
`BoardSerialNumber`. Present on newer Macs (2013+ at least) to avoid extra parsing of SMBIOS tables, especially in `boot.efi`.
- 4D1EDE05-38C7-4A6A-9CC6-4BCCA8B38C14:ROM  
Primary network adapter MAC address or replacement value. Present on newer Macs (2013+ at least) to avoid accessing special memory region, especially in `boot.efi`.

## 8.4 Recommended Variables

The following variables are recommended for faster startup or other improvements:

- `7C436110-AB2A-4BBB-A880-FE41995C9F82:csr-active-config`  
32-bit System Integrity Protection bitmask. Declared in XNU source code in `csr.h`.
- `4D1EDE05-38C7-4A6A-9CC6-4BCCA8B38C14:ExtendedFirmwareFeatures`  
Combined `FirmwareFeatures` and `ExtendedFirmwareFeatures`. Present on newer Macs to avoid extra parsing of SMBIOS tables
- `4D1EDE05-38C7-4A6A-9CC6-4BCCA8B38C14:ExtendedFirmwareFeaturesMask`  
Combined `FirmwareFeaturesMask` and `ExtendedFirmwareFeaturesMask`. Present on newer Macs to avoid extra parsing of SMBIOS tables.
- `4D1EDE05-38C7-4A6A-9CC6-4BCCA8B38C14:HW_BID`  
Hardware BoardProduct (e.g. `Mac-35C1E88140C3E6CF`). Not present on real Macs, but used to avoid extra parsing of SMBIOS tables, especially in `boot.efi`.
- `4D1EDE05-38C7-4A6A-9CC6-4BCCA8B38C14:HW_MLB`  
Hardware BoardSerialNumber. Override for MLB. Present on newer Macs (2013+ at least).
- `4D1EDE05-38C7-4A6A-9CC6-4BCCA8B38C14:HW_ROM`  
Hardware ROM. Override for ROM. Present on newer Macs (2013+ at least).
- `7C436110-AB2A-4BBB-A880-FE41995C9F82:prev-lang:kbd`  
ASCII string defining default keyboard layout. Format is `lang-COUNTRY:keyboard`, e.g. `ru-RU:19456` for Mac keyboard. Also accepts short forms: `ru:19456` or `ru:0`. Full decoded list of keyboards in `AppleKeyboardLayouts-L.dat` can be found on AppleLife.
- `7C436110-AB2A-4BBB-A880-FE41995C9F82:security-mode`  
ASCII string defining FireWire security mode. Legacy, can be found in `IOFireWireFamily` source code in `IOFireWireController.cpp`. It is recommended not to set this variable, which may speedup system startup. Setting to `full` is equivalent to not setting the variable and `none` disables FireWire security.
- `4D1EDE05-38C7-4A6A-9CC6-4BCCA8B38C14:UIScale`  
8-bit integer defining `boot.efi` user interface scaling. Should be 1 for normal screens and 2 for HDPI screens.

## 8.5 Other Variables

The following variables may be useful for certain configurations or troubleshooting:

- `7C436110-AB2A-4BBB-A880-FE41995C9F82:boot-args`  
Kernel arguments, used to pass configuration to Apple kernel and drivers. There are many arguments, which may be found by looking for the use of `PE_parse_boot_argn` function in the kernel or driver code.
  - `FIXME`: document several known values! `debug`, `keepsyms`, `slide`, `-v`, `-s`, `-x`, `cpus=x`, `io=x`, `kextlog=x`, `-nehalem_error_disable` `-no_compat_check` `nvda_drv=1`, etc?
- `7C436110-AB2A-4BBB-A880-FE41995C9F82:bootercfg`  
Booter arguments, similar to `boot-args` but for `boot.efi`. Accepts a set of arguments, which are hexadecimal 64-bit values with or without `0x` prefix primarily for logging control:
  - `log=VALUE`
    - \* 1 — `AppleLoggingConOutOrErrSet/AppleLoggingConOutOrErrPrint` (classical `ConOut/StdErr`)
    - \* 2 — `AppleLoggingStdErrSet/AppleLoggingStdErrPrint` (`StdErr` or `serial?`)
    - \* 4 — `AppleLoggingFileSet/AppleLoggingFilePrint` (`BOOTER.LOG/BOOTER.OLD` file on EFI partition)
  - `debug=VALUE`
    - \* 1 — enables print something to `BOOTER.LOG` (stripped code implies there may be a crash)
    - \* 2 — enables perf logging to `/efi/debug-log` in the device three
    - \* 4 — enables timestamp printing for styled `printf` calls
  - `level=VALUE` — Verbosity level of `DEBUG` output. Everything but `0x8000000` is stripped from the binary, and this is the default value.
  - `kc-read-size=VALUE` — Chunk size used for buffered I/O from network or disk for `prelinkedkernel` reading and related. Set to 1MB (`0x100000`) by default, can be tuned for faster booting.
- `7C436110-AB2A-4BBB-A880-FE41995C9F82:bootercfg-once`  
Booter arguments override removed after first launch. Otherwise equivalent to `bootercfg`.
- `7C436110-AB2A-4BBB-A880-FE41995C9F82:fmm-computer-name`
- `7C436110-AB2A-4BBB-A880-FE41995C9F82:nvda_drv`



## 9 PlatformInfo

Platform information is comprised of several identification fields generated or filled manually to be compatible with macOS services. The base part of the configuration may be obtained from `MacInfoPkg` package, which itself generates a set of interfaces based on a database in YAML format. These fields are written to three select destinations:

- SMBIOS
- Data Hub
- NVRAM

Most of the fields specify the overrides in SMBIOS, and their field names conform to EDK2 `SmBios.h` header file. However, several important fields reside in Data Hub and NVRAM. Some of the values can be found in more than one field and/or destination, so there are two ways to control their update process: manual, where one specifies all the values (the default), and semi-automatic, where (`Automatic`) only select values are specified, and later used for system configuration.

### 9.1 Properties

#### 1. `Automatic`

**Type:** plist boolean

**Default value:** false

**Description:** Generate PlatformInfo based on `Generic` section instead of using values from `DataHub`, `NVRAM`, and `SMBIOS` sections.

Enabling this option is useful when `Generic` section is flexible enough. When enabled `SMBIOS`, `DataHub`, and `PlatformNVRAM` data is unused.

#### 2. `UpdateDataHub`

**Type:** plist boolean

**Default value:** false

**Description:** Update DataHub fields. These fields are read from `Generic` or `DataHub` sections depending on `Automatic` value.

#### 3. `UpdateNVRAM`

**Type:** plist boolean

**Default value:** false

**Description:** Update NVRAM fields related to platform information.

These fields are read from `Generic` or `PlatformNVRAM` sections depending on `Automatic` value. All the other fields are to be specified with `NVRAM` section.

If `UpdateNVRAM` is set to `false` the aforementioned variables can be updated with `NVRAM` section. If `UpdateNVRAM` is set to `true` the behaviour is undefined when any of the fields are present in `NVRAM` section.

#### 4. `UpdateSMBIOS`

**Type:** plist boolean

**Default value:** false

**Description:** Update SMBIOS fields. These fields are read from `Generic` or `SMBIOS` sections depending on `Automatic` value.

#### 5. `UpdateSMBIOSMode`

**Type:** plist string

**Default value:** Auto

**Description:** Update SMBIOS fields approach:

- `Auto` — Overwrite if new size is  $\leq$  than the page-aligned original and there are no issues with legacy region unlock. `Create` otherwise.
- `Create` — Replace the tables with newly allocated `EfiReservedMemoryType` at `AllocateMaxAddress` without any fallbacks.
- `Overwrite` — Overwrite existing `gEfiSmbiosTableGuid` and `gEfiSmbiosTable3Guid` data if it fits new size. Abort with unspecified state otherwise.
- `Custom` — Write first SMBIOS table (`gEfiSmbiosTableGuid`) to `gOcCustomSmbiosTableGuid` to workaround firmwares overwriting SMBIOS contents at `ExitBootServices`. Otherwise equivalent to `Create`. Requires

patching AppleSmbios.kext and AppleACPIPlatform.kext to read from another GUID: "EB9D2D31" -> "EB9D2D35" (in ASCII).

6. Generic  
**Type:** plist dictionary  
**Optional:** When Automatic is false  
**Description:** Update all fields. This section is read only when Automatic is active.
7. DataHub  
**Type:** plist dictionary  
**Optional:** When Automatic is true  
**Description:** Update Data Hub fields. This section is read only when Automatic is not active.
8. PlatformNVRAM  
**Type:** plist dictionary  
**Optional:** When Automatic is true  
**Description:** Update platform NVRAM fields. This section is read only when Automatic is not active.
9. SMBIOS  
**Type:** plist dictionary  
**Optional:** When Automatic is true  
**Description:** Update SMBIOS fields. This section is read only when Automatic is not active.

## 9.2 Generic Properties

1. SystemProductName  
**Type:** plist string  
**Default value:** MacPro6,1  
**Description:** Refer to SMBIOS SystemProductName.
2. SystemSerialNumber  
**Type:** plist string  
**Default value:** OPENCORE\_SN1  
**Description:** Refer to SMBIOS SystemSerialNumber.
3. SystemUUID  
**Type:** plist string, GUID  
**Default value:** OEM specified  
**Description:** Refer to SMBIOS SystemUUID.
4. MLB  
**Type:** plist string  
**Default value:** OPENCORE\_MLB\_SN11  
**Description:** Refer to SMBIOS BoardSerialNumber.
5. ROM  
**Type:** plist data, 6 bytes  
**Default value:** all zero  
**Description:** Refer to 4D1EDE05-38C7-4A6A-9CC6-4BCCA8B38C14:ROM.

## 9.3 DataHub Properties

1. PlatformName  
**Type:** plist string  
**Default value:** Not installed  
**Description:** Sets name in gEfiMiscSubClassGuid. Value found on Macs is platform in ASCII.
2. SystemProductName  
**Type:** plist string  
**Default value:** Not installed  
**Description:** Sets Model in gEfiMiscSubClassGuid. Value found on Macs is equal to SMBIOS SystemProductName in Unicode.

3. SystemSerialNumber
 

**Type:** plist string  
**Default value:** Not installed  
**Description:** Sets SystemSerialNumber in gEfiMiscSubClassGuid. Value found on Macs is equal to SMBIOS SystemSerialNumber in Unicode.
4. SystemUUID
 

**Type:** plist string, GUID  
**Default value:** Not installed  
**Description:** Sets system-id in gEfiMiscSubClassGuid. Value found on Macs is equal to SMBIOS SystemUUID.
5. BoardProduct
 

**Type:** plist string  
**Default value:** Not installed  
**Description:** Sets board-id in gEfiMiscSubClassGuid. Value found on Macs is equal to SMBIOS BoardProduct in ASCII.
6. BoardRevision
 

**Type:** plist data, 1 byte  
**Default value:** 0  
**Description:** Sets board-rev in gEfiMiscSubClassGuid. Value found on Macs seems to correspond to internal board revision (e.g. 01).
7. StartupPowerEvents
 

**Type:** plist integer, 64-bit  
**Default value:** 0  
**Description:** Sets StartupPowerEvents in gEfiMiscSubClassGuid. Value found on Macs is power management state bitmask, normally 0. Known bits read by X86PlatformPlugin.kext:

  - 0x00000001 — Shutdown cause was a PWROK event (Same as GEN\_PMCON\_2 bit 0)
  - 0x00000002 — Shutdown cause was a SYS\_PWROK event (Same as GEN\_PMCON\_2 bit 1)
  - 0x00000004 — Shutdown cause was a THRMTRIP# event (Same as GEN\_PMCON\_2 bit 3)
  - 0x00000008 — Rebooted due to a SYS\_RESET# event (Same as GEN\_PMCON\_2 bit 4)
  - 0x00000010 — Power Failure (Same as GEN\_PMCON\_3 bit 1 PWR\_FLR)
  - 0x00000020 — Loss of RTC Well Power (Same as GEN\_PMCON\_3 bit 2 RTC\_PWR\_STS)
  - 0x00000040 — General Reset Status (Same as GEN\_PMCON\_3 bit 9 GEN\_RST\_STS)
  - 0xfffff80 — SUS Well Power Loss (Same as GEN\_PMCON\_3 bit 14)
  - 0x00010000 — Wake cause was a ME Wake event (Same as PRSTS bit 0, ME\_WAKE\_STS)
  - 0x00020000 — Cold Reboot was ME Induced event (Same as PRSTS bit 1 ME\_HRST\_COLD\_STS)
  - 0x00040000 — Warm Reboot was ME Induced event (Same as PRSTS bit 2 ME\_HRST\_WARM\_STS)
  - 0x00080000 — Shutdown was ME Induced event (Same as PRSTS bit 3 ME\_HOST\_PWRDN)
  - 0x00100000 — Global reset ME Watchdog Timer event (Same as PRSTS bit 6)
  - 0x00200000 — Global reset PowerManagement Watchdog Timer event (Same as PRSTS bit 15)
8. InitialTSC
 

**Type:** plist integer, 64-bit  
**Default value:** 0  
**Description:** Sets InitialTSC in gEfiProcessorSubClassGuid. Sets initial TSC value, normally 0.
9. FSBFrequency
 

**Type:** plist integer, 64-bit  
**Default value:** Automatic  
**Description:** Sets FSBFrequency in gEfiProcessorSubClassGuid. Sets CPU FSB frequency.
10. ARTFrequency
 

**Type:** plist integer, 64-bit  
**Default value:** Not installed  
**Description:** Sets ARTFrequency in gEfiProcessorSubClassGuid. Sets CPU ART frequency, Skylake and newer.
11. DevicePathsSupported
 

**Type:** plist data, 1 byte

**Default value:** Not installed

**Description:** Sets `DevicePathsSupported` in `gEfiMiscSubClassGuid`. Must be set to 01 for `AppleACPIPlatform.kext` to append SATA device paths to `Boot####` and `efi-boot-device-data` variables. Set to 01 on all modern Macs.

12. `SmcRevision`

**Type:** plist data, 6 bytes

**Default value:** Not installed

**Description:** Sets `REV` in `gEfiMiscSubClassGuid`. Custom property read by `VirtualSMC` or `FakeSMC` to generate SMC `REV` key.

13. `SmcBranch`

**Type:** plist data, 8 bytes

**Default value:** Not installed

**Description:** Sets `RBr` in `gEfiMiscSubClassGuid`. Custom property read by `VirtualSMC` or `FakeSMC` to generate SMC `RBr` key.

14. `SmcPlatform`

**Type:** plist data, 8 bytes

**Default value:** Not installed

**Description:** Sets `RP1t` in `gEfiMiscSubClassGuid`. Custom property read by `VirtualSMC` or `FakeSMC` to generate SMC `RP1t` key.

## 9.4 PlatformNVRAM Properties

1. `BID`

**Type:** plist string

**Default value:** Not installed

**Description:** Specifies the value of NVRAM variable `4D1EDE05-38C7-4A6A-9CC6-4BCCA8B38C14:HW_BID`.

2. `ROM`

**Type:** plist data, 6 bytes

**Default value:** Not installed

**Description:** Specifies the values of NVRAM variables `4D1EDE05-38C7-4A6A-9CC6-4BCCA8B38C14:HW_ROM` and `4D1EDE05-38C7-4A6A-9CC6-4BCCA8B38C14:ROM`.

3. `MLB`

**Type:** plist string

**Default value:** Not installed

**Description:** Specifies the values of NVRAM variables `4D1EDE05-38C7-4A6A-9CC6-4BCCA8B38C14:HW_MLB` and `4D1EDE05-38C7-4A6A-9CC6-4BCCA8B38C14:MLB`.

4. `FirmwareFeatures`

**Type:** plist data, 8 bytes

**Default value:** Not installed

**Description:** This variable comes in pair with `FirmwareFeaturesMask`. Specifies the values of NVRAM variables:

- `4D1EDE05-38C7-4A6A-9CC6-4BCCA8B38C14:FirmwareFeatures`
- `4D1EDE05-38C7-4A6A-9CC6-4BCCA8B38C14:ExtendedFirmwareFeatures`

5. `FirmwareFeaturesMask`

**Type:** plist data, 8 bytes

**Default value:** Not installed

**Description:** This variable comes in pair with `FirmwareFeatures`. Specifies the values of NVRAM variables:

- `4D1EDE05-38C7-4A6A-9CC6-4BCCA8B38C14:FirmwareFeaturesMask`
- `4D1EDE05-38C7-4A6A-9CC6-4BCCA8B38C14:ExtendedFirmwareFeaturesMask`

## 9.5 SMBIOS Properties

1. `BIOSVendor`

**Type:** plist string

**Default value:** OEM specified  
**SMBIOS:** BIOS Information (Type 0) — Vendor  
**Description:** BIOS Vendor. All rules of `SystemManufacturer` do apply.

## 2. BIOSVersion

**Type:** plist string

**Default value:** OEM specified

**SMBIOS:** BIOS Information (Type 0) — BIOS Version

**Description:** Firmware version. This value gets updated and takes part in update delivery configuration and macOS version compatibility. This value could look like `MM71.88Z.0234.B00.1809171422` in older firmwares, and is described in `BiosId.h`. In newer firmwares it should look like `236.0.0.0.0` or `220.230.16.0.0` (`iBridge:16.16.2542.0.0,0`). `iBridge` version is read from `BridgeOSVersion` variable, and is only present on macs with T2.

### Apple ROM Version

```
BIOS ID:      MBP151.88Z.F000.B00.1811142212
Model:       MBP151
EFI Version:  220.230.16.0.0
Built by:    root@quinoa
Date:       Wed Nov 14 22:12:53 2018
Revision:    220.230.16 (B&I)
ROM Version: F000_B00
Build Type:  Official Build, RELEASE
Compiler:    Apple LLVM version 10.0.0 (clang-1000.2.42)
UUID:       E5D1475B-29FF-32BA-8552-682622BA42E1
UUID:       151B0907-10F9-3271-87CD-4BF5DBECACF5
```

## 3. BIOSReleaseDate

**Type:** plist string

**Default value:** OEM specified

**SMBIOS:** BIOS Information (Type 0) — BIOS Release Date

**Description:** Firmware release date. Similar to `BIOSVersion`. May look like `12/08/2017`.

## 4. SystemManufacturer

**Type:** plist string

**Default value:** OEM specified

**SMBIOS:** System Information (Type 1) — Manufacturer

**Description:** OEM manufacturer of the particular board. Shall not be specified unless strictly required. Should *not* contain `Apple Inc.`, as this confuses numerous services present in the operating system, such as firmware updates, `eficheck`, as well as kernel extensions developed in `Acidanthera`, such as `Lilu` and its plugins.

## 5. SystemProductName

**Type:** plist string

**Default value:** OEM specified

**SMBIOS:** System Information (Type 1), Product Name

**Description:** Preferred Mac model used to mark the device as supported by the operating system. This value must be specified by any configuration for later automatic generation of the related values in this and other SMBIOS tables and related configuration parameters. If `SystemProductName` is not compatible with the target operating system, `-no_compat_check` boot argument may be used as an override.

*Note:* If `SystemProductName` is unknown, and related fields are unspecified, default values should be assumed as being set to `MacPro6,1` data. The list of known products can be found in `MacInfoPkg`.

## 6. SystemVersion

**Type:** plist string

**Default value:** OEM specified

**SMBIOS:** System Information (Type 1) — Version

**Description:** Product iteration version number. May look like `1.1`.

## 7. SystemSerialNumber

**Type:** plist string

**Default value:** OEM specified  
**SMBIOS:** System Information (Type 1) — Serial Number  
**Description:** Product serial number in defined format. Known formats are described in macserial.

8. SystemUUID  
**Type:** plist string, GUID  
**Default value:** OEM specified  
**SMBIOS:** System Information (Type 1) — UUID  
**Description:** A UUID is an identifier that is designed to be unique across both time and space. It requires no central registration process.
9. SystemSKUNumber  
**Type:** plist string  
**Default value:** OEM specified  
**SMBIOS:** System Information (Type 1) — SKU Number  
**Description:** Mac Board ID (board-id). May look like Mac-7BA5B2D9E42DDD94 or Mac-F221BEC8 in older models. Sometimes it can be just empty.
10. SystemFamily  
**Type:** plist string  
**Default value:** OEM specified  
**SMBIOS:** System Information (Type 1) — Family  
**Description:** Family name. May look like iMac Pro.
11. BoardManufacturer  
**Type:** plist string  
**Default value:** OEM specified  
**SMBIOS:** Baseboard (or Module) Information (Type 2) - Manufacturer  
**Description:** Board manufacturer. All rules of SystemManufacturer do apply.
12. BoardProduct  
**Type:** plist string  
**Default value:** OEM specified  
**SMBIOS:** Baseboard (or Module) Information (Type 2) - Product  
**Description:** Mac Board ID (board-id). May look like Mac-7BA5B2D9E42DDD94 or Mac-F221BEC8 in older models.
13. BoardVersion  
**Type:** plist string  
**Default value:** OEM specified  
**SMBIOS:** Baseboard (or Module) Information (Type 2) - Version  
**Description:** Board version number. Varies, may match SystemProductName or SystemProductVersion.
14. BoardSerialNumber  
**Type:** plist string  
**Default value:** OEM specified  
**SMBIOS:** Baseboard (or Module) Information (Type 2) — Serial Number  
**Description:** Board serial number in defined format. Known formats are described in macserial.
15. BoardAssetTag  
**Type:** plist string  
**Default value:** OEM specified  
**SMBIOS:** Baseboard (or Module) Information (Type 2) — Asset Tag  
**Description:** Asset tag number. Varies, may be empty or Type2 - Board Asset Tag.
16. BoardType  
**Type:** plist integer  
**Default value:** OEM specified  
**SMBIOS:** Baseboard (or Module) Information (Type 2) — Board Type  
**Description:** Either 0xA (Motherboard (includes processor, memory, and I/O) or 0xB (Processor/Memory Module), refer to Table 15 – Baseboard: Board Type for more details.

17. **BoardLocationInChassis**  
**Type:** plist string  
**Default value:** OEM specified  
**SMBIOS:** Baseboard (or Module) Information (Type 2) — Location in Chassis  
**Description:** Varies, may be empty or Part Component.
18. **ChassisManufacturer**  
**Type:** plist string  
**Default value:** OEM specified  
**SMBIOS:** System Enclosure or Chassis (Type 3) — Manufacturer  
**Description:** Board manufacturer. All rules of **SystemManufacturer** do apply.
19. **ChassisType**  
**Type:** plist integer  
**Default value:** OEM specified  
**SMBIOS:** System Enclosure or Chassis (Type 3) — Type  
**Description:** Chassis type, refer to Table 17 — System Enclosure or Chassis Types for more details.
20. **ChassisVersion**  
**Type:** plist string  
**Default value:** OEM specified  
**SMBIOS:** System Enclosure or Chassis (Type 3) — Version  
**Description:** Should match **BoardProduct**.
21. **ChassisSerialNumber**  
**Type:** plist string  
**Default value:** OEM specified  
**SMBIOS:** System Enclosure or Chassis (Type 3) — Version  
**Description:** Should match **SystemSerialNumber**.
22. **ChassisAssetTag**  
**Type:** plist string  
**Default value:** OEM specified  
**SMBIOS:** System Enclosure or Chassis (Type 3) — Asset Tag Number  
**Description:** Chassis type name. Varies, could be empty or MacBook-Aluminum.
23. **PlatformFeature**  
**Type:** plist integer  
**Default value:** 0  
**SMBIOS:** APPLE\_SMBIOS\_TABLE\_TYPE133 - PlatformFeature  
**Description:** Platform features bitmask. Refer to AppleFeatures.h for more details.
24. **FirmwareFeatures**  
**Type:** plist data, 8 bytes  
**Default value:** 0  
**SMBIOS:** APPLE\_SMBIOS\_TABLE\_TYPE128 - FirmwareFeatures and ExtendedFirmwareFeatures  
**Description:** 64-bit firmware features bitmask. Refer to AppleFeatures.h for more details. Lower 32 bits match **FirmwareFeatures**. Upper 64 bits match **ExtendedFirmwareFeatures**.
25. **FirmwareFeaturesMask**  
**Type:** plist data, 8 bytes  
**Default value:** 0  
**SMBIOS:** APPLE\_SMBIOS\_TABLE\_TYPE128 - FirmwareFeaturesMask and ExtendedFirmwareFeaturesMask  
**Description:** Supported bits of extended firmware features bitmask. Refer to AppleFeatures.h for more details. Lower 32 bits match **FirmwareFeaturesMask**. Upper 64 bits match **ExtendedFirmwareFeaturesMask**.
26. **ProcessorType**  
**Type:** plist integer, 16-bit  
**Default value:** Automatic  
**SMBIOS:** APPLE\_SMBIOS\_TABLE\_TYPE131 - ProcessorType  
**Description:** Combined of Processor Major and Minor types.

27. MemoryFormFactor

**Type:** plist integer, 8-bit

**Default value:** OEM specified

**SMBIOS:** Memory Device (Type 17) — Form Factor

**Description:** Memory form factor. On Macs it should be DIMM or SODIMM.



## 10 UEFI

### 10.1 Introduction

UEFI (Unified Extensible Firmware Interface) is a specification that defines a software interface between an operating system and platform firmware. This section allows to load additional UEFI modules and/or apply tweaks for the onboard firmware.

### 10.2 Properties

#### 1. ConnectDrivers

**Type:** plist boolean

**Default value:** NO

**Description:** Perform UEFI controller connection after driver loading. This option is useful for loading filesystem drivers, which usually follow UEFI driver model, and may not start by themselves. While effective, this option is not necessary with e.g. APFS loader driver, and may slightly slowdown the boot.

#### 2. Drivers

**Type:** plist array

**Default value:** None

**Description:** Load selected drivers from `OC/Drivers` directory.

Designed to be filled with string filenames meant to be loaded as UEFI drivers. Depending on the firmware a different set of drivers may be required. Loading an incompatible driver may lead your system to unbootable state or even cause permanent firmware damage. Some of the known drivers include:

- **ApfsDriverLoader** — APFS file system bootstrap driver adding the support of embedded APFS drivers in bootable APFS containers in UEFI firmwares.
- **AppleUiSupport** — Apple-specific user interface support driver. This driver brings the support for FileVault 2 GUI, hotkey parsing (shift, cmd+v, etc.), language collation support, and certain other features important for normal macOS functioning. For hotkey support **AppleKeyMapAggregator**-compatible driver is required.
- **AptioInputFix** — user input driver adding the support of **AppleKeyMapAggregator** protocols on top of different UEFI input protocols. Additionally resolves mouse input issues on select firmwares. This is an alternative to **UsbKbDxe**, which may work better or worse depending on the firmware.
- **AptioMemoryFix** — a set of quirks for various firmwares. While it primarily targets APTIO firmwares, other firmwares may be compatible as well. Among the resolved issues are hibernation support, KASLR, Lilu NVRAM security enhancements, NVRAM, and UEFI Boot entry preservation.
- **DataHubDxe** — Intel DataHub driver from **IntelFrameworkModulePkg**. It is believed that this driver is included in all UEFI firmwares, and is not required.
- **EmuVariableRuntimeDxe** — NVRAM emulation driver from **MdeModulePkg**. NVRAM is supported by most modern firmwares. For firmwares with macOS incompatible NVRAM implementation an emulated driver may be used. This driver will not preserve NVRAM contents across the reboots.
- **EnglishDxe** — Unicode collation driver from **MdeModulePkg**. This driver is a lightweight alternative to **AppleUiSupport**, which contains no Apple-specific code, and only provides unicode collation support. The driver is not recommended for use on any hardware but few original Macs.
- **EnhancedFatDxe** — FAT filesystem driver from **FatPkg**. This driver is embedded in all UEFI firmwares, and cannot be used from OpenCore. It is known that multiple firmwares have a bug in their FAT support implementation, which leads to corrupted filesystems on write attempt. Embedding this driver within the firmware may be required in case writing to EFI partition is needed during the boot process.
- **NvmExpressDxe** — NVMe support driver from **MdeModulePkg**. This driver is included in most firmwares starting with Broadwell generation. For Haswell and earlier embedding it within the firmware may be more favourable in case a NVMe SSD drive is installed.
- **UsbKbDxe** — USB keyboard driver adding the support of **AppleKeyMapAggregator** protocols on top of a custom USB keyboard driver implementation. This is an alternative to **AptioInputFix**, which may work better or worse depending on the firmware.
- **VirtualSmc** — UEFI SMC driver, required for proper FileVault 2 functionality and potentially other macOS specifics. An alternative, named **SMCHelper**, is not compatible with **VirtualSmc** and OpenCore, which is unaware of its specific interfaces. In case **FakeSMC** kernel extension is used, manual NVRAM variable addition may be needed and **VirtualSmc** driver should still be used.

- **VBoxHfs** — HFS file system driver with bless support. This driver is an alternative to a closed source **HFSPPlus** driver commonly found in Apple firmwares. While it is feature complete, it is approximately 3 times slower and is yet to undergo a security audit.

To compile the drivers from TianoCore UDK use the same command you do normally use for OpenCore compilation, but choose a corresponding package:

---

```
git clone https://github.com/tianocore/edk2 -b UDK2018 UDK
cd UDK
source edksetup.sh
make -C BaseTools
build -a X64 -b RELEASE -t XCODE5 -p FatPkg/FatPkg.dsc
build -a X64 -b RELEASE -t XCODE5 -p MdeModulePkg/MdeModulePkg.dsc
build -a X64 -b RELEASE -t XCODE5 -p IntelFrameworkModulePkg/IntelFrameworkModulePkg.dsc
```

---

### 3. Protocols

**Type:** plist dict

**Default value:** None

**Description:** Force builtin versions of select protocols described in Protocols Properties section below.

### 4. Quirks

**Type:** plist dict

**Default value:** None

**Description:** Apply individual firmware quirks described in Quirks Properties section below.

## 10.3 Protocols Properties

### 1. AppleBootPolicy

**Type:** plist boolean

**Default value:** false

**Description:** Reinstalls apple boot policy protocol with a builtin version. This may be used to ensure APFS compatibility on VMs or legacy Macs.

### 2. DeviceProperties

**Type:** plist boolean

**Default value:** false

**Description:** Reinstalls device property protocol with a builtin version. This will drop all previous properties if it was already installed. This may be used to ensure full compatibility on VMs or legacy Macs.

## 10.4 Quirks Properties

### 1. ExitBootServicesDelay

**Type:** plist integer

**Default value:** 0

**Description:** Adds delay in microseconds after `EXIT_BOOT_SERVICES` event.

This is a very ugly quirk to circumvent "Still waiting for root device" message on select APTIO IV firmwares, namely ASUS Z87-Pro, when using FileVault 2 in particular. It seems that for some reason they execute code in parallel to `EXIT_BOOT_SERVICES`, which results in SATA controller being inaccessible from macOS. A better approach should be found in some future. Expect 3-5 seconds to be enough in case the quirk is needed.

### 2. IgnoreInvalidFlexRatio

**Type:** plist boolean

**Default value:** NO

**Description:** Select firmwares, namely APTIO IV, may contain invalid values in `MSR_FLEX_RATIO` (0x194) MSR register. These values may cause macOS boot failure on Intel platforms.

*Note:* While the option is not supposed to induce harm on unaffected firmwares, its usage is not recommended when it is not required.

### 3. IgnoreTextInGraphics

**Type:** plist boolean

**Default value:** NO

**Description:** Select firmwares output text onscreen in both graphics and text mode. This is normally unexpected, because random text may appear over graphical images and cause UI corruption. Setting this option to `true` will discard all text output when console control is in mode different from `Text`.

*Note:* While the option is not supposed to induce harm on unaffected firmwares, its usage is not recommended when it is not required. This option may hide onscreen error messages. `ProvideConsoleControl` is required to be set to `true` for this to work.

4. `ProvideConsoleControl`

**Type:** plist boolean

**Default value:** NO

**Description:** macOS bootloader requires console control protocol for text output, some firmwares miss it. This option is required to be set when other console control options are used, such as `IgnoreTextInGraphics`, `SanitiseClearScreen`, and sometimes `ConsoleBehaviourOs` with `ConsoleBehaviourUi`).

5. `ProvideConsoleGop`

**Type:** plist boolean

**Default value:** NO

**Description:** macOS bootloader requires GOP (Graphics Output Protocol) to be present on console handle. This option will install it if missing.

*Note:* Some drivers, like `AptioMemoryFix`, may provide equivalent functionality. These drivers are not guaranteed to adhere to the same logic, and if a quirk is necessary, this option is preferred.

6. `ReleaseUsbOwnership`

**Type:** plist boolean

**Default value:** false

**Description:** Attempt to detach USB controller ownership from the firmware driver. While most firmwares manage to properly do that, or at least have an option for, select firmwares do not. As a result, operating system may freeze upon boot. Not recommended unless required.

7. `RequestBootVarRouting`

**Type:** plist boolean

**Default value:** false

**Description:** Request NVRAM driver (or `AptioMemoryFix`) to redirect `Boot` prefixed variables from `EFI_GLOBAL_VARIABLE_GUID` to `OC_VENDOR_VARIABLE_GUID`.

This will set special `boot-redirect` variable, which a compatible driver will abide after booter start. The quirk lets default boot entry preservation at times when firmwares delete incompatible boot entries.

8. `SanitiseClearScreen`

**Type:** plist boolean

**Default value:** false

**Description:** Some firmwares reset screen resolution to a failsafe value (like `1024x768`) on the attempts to clear screen contents when large display (e.g. `2K` or `4K`) is used. This option attempts to apply a workaround.

*Note:* `ProvideConsoleControl` is required to be set to `true` for this to work. On all known affected systems `ConsoleMode` had to be set to empty string for this to work.

# 11 Troubleshooting

## 11.1 Tips and Tricks

### 1. How to debug boot failure?

Normally it is enough to obtain the actual error message. For this ensure that:

- You have a `DEBUG` or `NOOPT` version of OpenCore.
- Logging is enabled (1) and shown onscreen (2): `Misc → Debug → Target = 3`.
- Logged messages from at least `DEBUG_ERROR` (0x80000000), `DEBUG_WARN` (0x00000002), and `DEBUG_INFO` (0x00000040) levels are visible onscreen: `Misc → Debug → DisplayLevel = 0x80000042`.
- Critical error messages, like `DEBUG_ERROR`, stop booting: `Misc → Security → HaltLevel = 0x80000000`.
- Watch Dog is disabled to prevent automatic reboot: `Uefi → Quirks → DisableWatchDog = true`.
- Boot Picker (entry selector) is enabled: `Misc → Boot → ShowPicker = true`.

If there is no obvious error, check the available hacks in `Quirks` sections one by one.

### 2. How to customise boot entries?

OpenCore follows standard Apple Bless model and extracts the entry name from `.contentDetails` and `.disk_label.contentDetails` files in the booter directory if present. These files contain an ASCII string with an entry title, which may then be customised by the user.

### 3. What is the simplest way to install macOS?

Copy online recovery image (`*.dmg` and `*.chunklist` files) to `com.apple.recovery.boot` directory on a FAT32 partition with OpenCore. Load OpenCore Boot Picker and choose the entry, it will have a `(dmg)` suffix. Custom name may be created by providing `.contentDetails` file.

To download recovery online you may use Recovery tool from `OcSupportPkg`.