

OpenCore

Reference Manual (0.0.2)

[2019.05.09]

Contents

1	Introduction	3
1.1	Known defects	3
2	Generic Terms	4
3	Overview	5
3.1	Configuration Terms	5
3.2	Configuration Processing	5
3.3	Configuration Structure	6
3.4	Directory Structure	6
3.5	Contribution	7
4	ACPI	9
4.1	Introduction	9
4.2	Properties	9
4.3	Add Properties	9
4.4	Block Properties	10
4.5	Patch Properties	10
4.6	Quirks Properties	11
5	DeviceProperties	13
5.1	Introduction	13
5.2	Properties	13
5.3	Common Properties	13
6	Kernel	14
6.1	Introduction	14
6.2	Properties	14
6.3	Add Properties	14
6.4	Block Properties	15
6.5	Patch Properties	15
6.6	Quirks Properties	16
7	Misc	18
7.1	Introduction	18
7.2	Properties	18
7.3	Boot Properties	18
7.4	Debug Properties	19
7.5	Security Properties	20
8	NVRAM	22
8.1	Introduction	22
8.2	Properties	22
8.3	Mandatory Variables	22
8.4	Recommended Variables	23
8.5	Other Variables	23
9	PlatformInfo	25
9.1	Properties	25
9.2	Generic Properties	26
9.3	DataHub Properties	26
9.4	PlatformNVRAM Properties	28
9.5	SMBIOS Properties	29
10	UEFI	33
10.1	Introduction	33

10.2 Properties	33
10.3 Protocols Properties	34
10.4 Quirks Properties	34
11 Troubleshooting	36
11.1 Tips and Tricks	36

1 Introduction

This document provides information on OpenCore user configuration file format used to setup the correct functioning of macOS operating system.

1.1 Known defects

For OpenCore issues please refer to Acidanthera Bugtracker.

2 Generic Terms

- **plist** — Subset of ASCII Property List format written in XML, also known as XML plist format version 1. Uniform Type Identifier (UTI): `com.apple.property-list`. Plists consist of **plist objects**, which are combined to form a hierarchical structure. Due to plist format not being well-defined, all the definitions of this document may only be applied after plist is considered valid by running `plutil -lint`. External references: <https://www.apple.com/DTDs/PropertyList-1.0.dtd>, `man plutil`.
- **plist type** — plist collections (**plist array**, **plist dictionary**, **plist key**) and primitives (**plist string**, **plist data**, **plist date**, **plist boolean**, **plist integer**, **plist real**).
- **plist object** — definite realisation of **plist type**, which may be interpreted as value.
- **plist array** — array-like collection, conforms to **array**. Consists of zero or more **plist objects**.
- **plist dictionary** — map-like (associative array) collection, conforms to **dict**. Consists of zero or more **plist keys**.
- **plist key** — contains one **plist object** going by the name of **plist key**, conforms to **key**. Consists of printable 7-bit ASCII characters.
- **plist string** — printable 7-bit ASCII string, conforms to **string**.
- **plist data** — base64-encoded blob, conforms to **data**.
- **plist date** — ISO-8601 date, conforms to **date**, unsupported.
- **plist boolean** — logical state object, which is either true (1) or false (0), conforms to **true** and **false**.
- **plist integer** — possibly signed integer number in base 10, conforms to **integer**. Fits in 64-bit unsigned integer in two's complement representation, unless a smaller signed or unsigned integral type is explicitly mentioned in specific **plist object** description.
- **plist real** — floating point number, conforms to **real**, unsupported.
- **plist metadata** — value cast to data by the implementation. Permits passing **plist string**, in which case the result is represented by a null-terminated sequence of bytes (aka C string), **plist integer**, in which case the result is represented by *32-bit* little endian sequence of bytes in two's complement representation, **plist boolean**, in which case the value is one byte: 01 for **true** and 00 for **false**, and **plist data** itself. All other types or larger integers invoke undefined behaviour.

3 Overview

3.1 Configuration Terms

- **OC config** — OpenCore Configuration file in `plist` format named `config.plist`. It has to provide extensible way to configure OpenCore and is structured to be separated into multiple named sections situated in the root `plist` dictionary. These sections are permitted to have `plist array` or `plist dictionary` types and are described in corresponding sections of this document.
- **valid key** — `plist key` object of **OC config** described in this document or its future revisions. Besides explicitly described **valid keys**, keys starting with `#` symbol (e.g. `#Hello`) are also considered **valid keys** and behave as comments, effectively discarding their value, which is still required to be a **valid plist object**. All other `plist keys` are not valid, and their presence yields to **undefined behaviour**.
- **valid value** — **valid plist object** of **OC config** described in this document that matches all the additional requirements in specific `plist object` description if any.
- **invalid value** — **valid plist object** of **OC config** described in this document that is of other `plist type`, does not conform to additional requirements found in specific `plist object` description (e.g. value range), or missing from the corresponding collection. **Invalid value** is read with or without an error message as any possible value of this `plist object` in an undetermined manner (i.e. the values may not be same across the reboots). Whilst reading an **invalid value** is equivalent to reading certain defined **valid value**, applying incompatible value to the host system may yield to **undefined behaviour**.
- **optional value** — **valid value** of **OC config** described in this document that reads in a certain defined manner provided in specific `plist object` description (instead of **invalid value**) when not present in **OC config**. All other cases of **invalid value** do still apply. Unless explicitly marked as **optional value**, any other value is required to be present and reads to **invalid value** if missing.
- **fatal behaviour** — behaviour leading to boot termination. Implementation must stop the boot process from going any further until next host system boot. It is allowed but not required to perform cold reboot or show any warning message.
- **undefined behaviour** — behaviour not prescribed by this document. Implementation is allowed to take any measures including but not limited to **fatal behaviour**, assuming any states or values, or ignoring, unless these measures negatively affect system security in general.

3.2 Configuration Processing

OC config is guaranteed to be processed at least once if it was found. Depending on OpenCore bootstrapping mechanism multiple **OC config** files may lead to reading any of them. No **OC Config** may be present on disk, in which case all the values read follow the rules of **invalid value** and **optional value**.

OC config has size, nesting, and key amount limitations. **OC config** size does not exceed 16 MBs. **OC config** has no more than 8 nesting levels. **OC config** has up to 16384 XML nodes (i.e. one `plist dictionary` item is counted as a pair of nodes) within each `plist object`.

Reading malformed **OC config** file leads to **undefined behaviour**. Examples of malformed **OC config** cover at least the following cases:

- files non-conformant to `plist` DTD
- files with unsupported or non-conformant `plist objects` found in this document
- files violating size, nesting, and key amount limitations

It is recommended but not required to abort loading malformed **OC config** and continue as if no **OC config** was present. For forward compatibility it is recommended but not required for the implementation to warn about the use of **invalid values**. Recommended practice of interpreting **invalid values** is to conform to the following convention where applicable:

Type	Value
<code>plist string</code>	Empty string (<code><string></string></code>)
<code>plist data</code>	Empty data (<code><data></data></code>)

Type	Value
<code>plist integer</code>	0 (<integer>0</integer>)
<code>plist boolean</code>	False (<false/>)
<code>plist tristate</code>	False (<false/>)

3.3 Configuration Structure

OC `config` is separated into following sections, which are described in separate sections of this document. By default it is tried to not enable anything and optionally provide kill switches with `Enable` property for `plist dict` entries. In general the configuration is written idiomatically to group similar actions in subsections:

- `Add` provides support for data addition.
- `Block` provides support for data removal or ignorance.
- `Patch` provides support for data modification.
- `Quirks` provides support for specific hacks.

Root configuration entries consist of the following:

- `ACPI`
- `DeviceProperties`
- `Kernel`
- `Misc`
- `NVRAM`
- `PlatformInfo`
- `UEFI`

Note: Currently most properties try to have defined values even if not specified in the configuration for safety reasons. This behaviour should not be relied upon, and all fields must be properly specified in the configuration.

3.4 Directory Structure

When directory boot is used the directory structure used should follow the description on Directory Structure figure. Available entries include:

- `BOOTx64.efi`
Initial booter, which loads `OpenCore.efi` unless it was already started as a driver.
- `ACPI`
Directory used for storing supplemental ACPI information for `ACPI` section.
- `Drivers`
Directory used for storing supplemental UEFI drivers for `UEFI` section.
- `Kexts`
Directory used for storing supplemental kernel information for `Kernel` section.
- `OpenCore.efi`
Main booter driver responsible for operating system loading.
- `vault.plist`
Hashes for all files potentially loadable by OC `Config`.
- `config.plist`
OC `Config`.
- `vault.sig`
Signature for `vault.plist`.

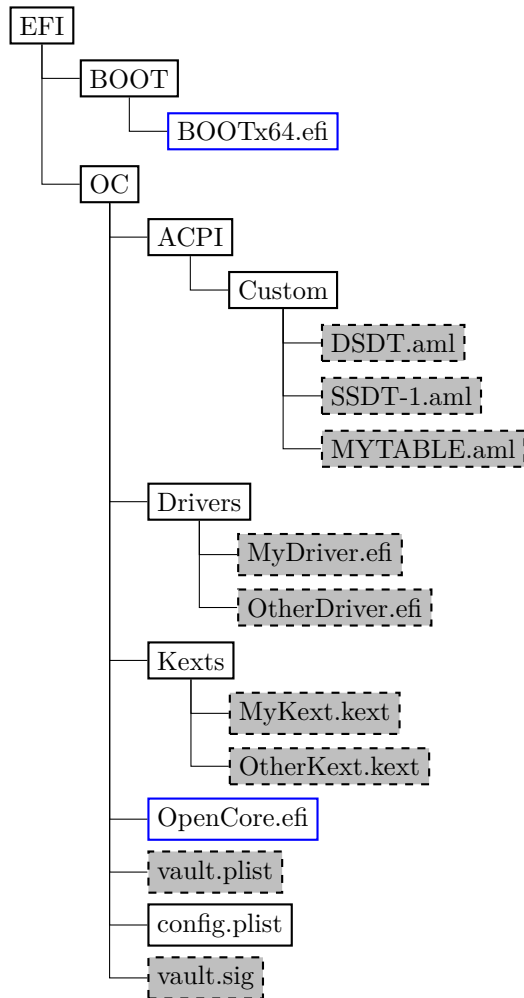

Figure 1. Directory Structure

3.5 Contribution

OpenCore can be compiled as an ordinary EDK II package with UDK 2018.

The only officially supported toolchain is XCODE5. Other toolchains might work, but are neither supported, nor recommended. Contribution of clean patches is welcome. Please do follow EDK II C Codestyle.

Required external package dependencies include EfiPkg, MacInfoPkg, and OcSupportPkg.

To compile with XCODE5, besides Xcode, one should also install NASM and MTOC. Example command sequence may look as follows:

```

git clone https://github.com/tianocore/edk2 -b UDK2018 UDK
cd UDK
git clone https://github.com/acidanthera/EfiPkg
git clone https://github.com/acidanthera/MacInfoPkg
git clone https://github.com/acidanthera/OcSupportPkg
git clone https://github.com/acidanthera/OpenCorePkg
source edksetup.sh
make -C BaseTools
build -a X64 -b RELEASE -t XCODE5 -p OpenCorePkg/OpenCorePkg.dsc
  
```

Listing 1: Compilation Commands

NOOPT or DEBUG build modes instead of RELEASE can produce a lot more debug output. With NOOPT source level debugging with GDB or IDA Pro is also available. For GDB check OcSupport Debug page. For IDA Pro you will need IDA Pro 7.3 or newer.

For IDE usage Xcode projects are available in the root of the repositories. Another approach could be Sublime Text with EasyClangComplete plugin. Add `.clang_complete` file with similar content to your UDK root:

```
-I/UefiPackages/MdePkg
-I/UefiPackages/MdePkg/Include
-I/UefiPackages/MdePkg/Include/X64
-I/UefiPackages/EfiPkg
-I/UefiPackages/EfiPkg/Include
-I/UefiPackages/EfiPkg/Include/X64
-I/UefiPackages/AptioFixPkg/Include
-I/UefiPackages/AppleSupportPkg/Include
-I/UefiPackages/OpenCorePkg/Include
-I/UefiPackages/OcSupportPkg/Include
-I/UefiPackages/IntelFrameworkPkg/Include
-I/UefiPackages/MacInfoPkg/Include
-IInclude
-include
/UefiPackages/MdePkg/Include/Uefi.h
-fshort-wchar
-Wall
-Wextra
-Wno-unused-parameter
-Wno-missing-braces
-Wno-missing-field-initializers
-Wno-tautological-compare
-Wno-sign-compare
-Wno-varargs
-Wno-unused-const-variable
```

Listing 2: ECC Configuration

Warning: Tool developers modifying `config.plist` or any other OpenCore files must ensure that their tool checks for `opencore-version` NVRAM variable (see Debug Properties section below) and warn the user if the version listed is unsupported or prerelease. OpenCore configuration may change across the releases and the tool shall ensure that it carefully follows this document. Failure to do so may result in this tool to be considered as malware and blocked with all possible means.

4 ACPI

4.1 Introduction

ACPI (Advanced Configuration and Power Interface) is an open standard to discover and configure computer hardware. ACPI specification defines the standard tables (e.g. DSDT, SSDT, FACS, DMAR) and various methods (e.g. _DSM, _PWR) for implementation. Modern hardware needs little changes to maintain ACPI compatibility, yet some of those are provided as a part of OpenCore.

4.2 Properties

1. Add

Type: plist array

Default value: Empty

Description: Load selected tables from OC/ACPI/Custom directory.

Designed to be filled with `plist dict` values, describing each block entry. See Add Properties section below.

2. Block

Type: plist array

Default value: Empty

Description: Remove selected tables from ACPI stack.

Designed to be filled with `plist dict` values, describing each block entry. See Block Properties section below.

3. Patch

Type: plist array

Default value: Empty

Description: Perform binary patches in ACPI tables before table addition or removal.

Designed to be filled with `plist dictionary` values describing each patch entry. See Patch Properties section below.

4. Quirks

Type: plist dict

Description: Apply individual ACPI quirks described in Quirks Properties section below.

4.3 Add Properties

1. Comment

Type: plist string

Default value: Empty string

Description: Arbitrary ASCII string used to provide human readable reference for the entry. It is implementation defined whether this value is used.

2. Enabled

Type: plist boolean

Default value: false

Description: This ACPI table will not be added unless set to `true`.

3. Path

Type: plist string

Default value: Empty string

Description: File paths meant to be loaded as ACPI tables. Example values include `DSDT.aml`, `SubDir/SSDT-8.aml`, `SSDT-USBX.aml`, etc.

ACPI table load order follows the item order in the array. All ACPI tables load from OC/ACPI/Custom directory.

Note: All tables but tables with DSDT table identifier (determined by parsing data not by filename) insert new tables into ACPI stack. DSDT, unlike the rest, performs replacement of DSDT table.

4.4 Block Properties

1. All
Type: plist boolean
Default value: false
Description: If set to `true`, all ACPI tables matching the condition will be dropped. Otherwise only first matched table.
2. Comment
Type: plist string
Default value: Empty string
Description: Arbitrary ASCII string used to provide human readable reference for the entry. It is implementation defined whether this value is used.
3. Enabled
Type: plist boolean
Default value: false
Description: This ACPI table will not be removed unless set to `true`.
4. OemTableId
Type: plist data, 8 bytes
Default value: All zero
Description: Match table OEM ID to be equal to this value unless all zero.
5. TableLength
Type: plist integer
Default value: 0
Description: Match table size to be equal to this value unless 0.
6. TableSignature
Type: plist data, 4 bytes
Default value: All zero
Description: Match table signature to be equal to this value unless all zero.

4.5 Patch Properties

1. Comment
Type: plist string
Default value: Empty string
Description: Arbitrary ASCII string used to provide human readable reference for the entry. It is implementation defined whether this value is used.
2. Count
Type: plist integer
Default value: 0
Description: Number of patch occurrences to apply. 0 applies the patch to all occurrences found.
3. Enabled
Type: plist boolean
Default value: false
Description: This ACPI patch will not be used unless set to `true`.
4. Find
Type: plist data
Default value: Empty data
Description: Data to find. Must equal to `Replace` in size.
5. Limit
Type: plist integer
Default value: 0
Description: Maximum number of bytes to search for. Can be set to 0 to look through the whole ACPI table.

6. **Mask**
Type: plist data
Default value: Empty data
Description: Data bitwise mask used during find comparison. Allows fuzzy search by ignoring not masked (set to zero) bits. Can be set to empty data to be ignored. Must equal to **Replace** in size otherwise.
7. **OemTableId**
Type: plist data, 8 bytes
Default value: All zero
Description: Match table OEM ID to be equal to this value unless all zero.
8. **Replace**
Type: plist data
Default value: Empty data
Description: Replacement data of one or more bytes.
9. **ReplaceMask**
Type: plist data
Default value: Empty data
Description: Data bitwise mask used during replacement. Allows fuzzy replacement by updating masked (set to non-zero) bits. Can be set to empty data to be ignored. Must equal to **Replace** in size otherwise.
10. **Skip**
Type: plist integer
Default value: 0
Description: Number of found occurrences to be skipped before replacement is done.
11. **TableLength**
Type: plist integer
Default value: 0
Description: Match table size to be equal to this value unless 0.
12. **TableSignature**
Type:
textttplist data, 4 bytes
Default value: All zero
Description: Match table signature to be equal to this value unless all zero.

In the majority of the cases ACPI patches are not useful and harmful:

- Avoid renaming devices with ACPI patches. This may fail or perform improper renaming of unrelated devices (e.g. EC and ECO), be unnecessary, or even fail to rename devices in select tables. For ACPI consistency it is much safer to rename devices at I/O Registry level, as done by WhateverGreen.
- Avoid patching `_OSI` to support a higher level of feature sets unless absolutely required. Commonly this enables a number of hacks on APTIO firmwares, which result in the need to add more patches. Modern firmwares generally do not need it at all, and those that do are fine with much smaller patches.
- Try to avoid hacky changes like renaming `_PWR` or `_DSM` whenever possible.

Several cases, where patching actually does make sense, include:

- Refreshing HPET (or another device) method header to avoid compatibility checks by `_OSI` on legacy hardware. `_STA` method with `if ((OSFL () == Zero)) { If (HPTE) ... Return (Zero)` content may be forced to always return 0xF by replacing `A0 10 93 4F 53 46 4C 00` with `A4 0A 0F A3 A3 A3 A3`.
- To provide custom method implementation with in an SSDT, for instance, to report functional key presses on a laptop, the original method can be replaced with a dummy name by patching `_Q11` with `XQ11`.

Tianocore AcpiAml.h source file may help understanding ACPI opcodes.

4.6 Quirks Properties

1. **FadtEnableReset**
Type: plist boolean

Default value: false

Description: Provide reset register and flag in FADT table to enable reboot and shutdown on legacy hardware. Not recommended unless required.

2. `IgnoreForWindows`

Type: plist boolean

Default value: false

Description: Disable all sorts of ACPI modifications when booting Windows operating system.

This flag implements a quick workaround for those, who made their ACPI tables incompatible with Windows, but need it right now. Not recommended, as ACPI tables must be compatible with any operating system regardless of the changes.

Note: This option may be removed in the future.

3. `NormalizeHeaders`

Type: plist boolean

Default value: false

Description: Cleanup ACPI header fields to workaround macOS ACPI implementation bug causing boot crashes. Reference: Debugging AppleACPIPlatform on 10.13 by Alex James aka theracermaster. The issue is fixed in macOS Mojave (10.14).

4. `RebaseRegions`

Type: plist boolean

Default value: false

Description: Attempt to heuristically relocate ACPI memory regions. Not recommended.

ACPI tables are often generated dynamically by underlying firmware implementation. Among the position-independent code, ACPI tables may contain physical addresses of MMIO areas used for device configuration, usually grouped in regions (e.g. `OperationRegion`). Changing firmware settings or hardware configuration, upgrading or patching the firmware inevitably leads to changes in dynamically generated ACPI code, which sometimes lead to the shift of the addresses in aforementioned `OperationRegion` constructions.

For this reason it is very dangerous to apply any kind of modifications to ACPI tables. The most reasonable approach is to make as few as possible changes to ACPI and try to not replace any tables, especially DSDT. When this is not possible, then at least attempt to ensure that custom DSDT is based on the most recent DSDT or remove writes and reads for the affected areas.

When nothing else helps this option could be tried to avoid stalls at `PCI Configuration Begin` phase of macOS booting by attempting to fix the ACPI addresses. It does not do magic, and only works with most common cases. Do not use unless absolutely required.

5. `ResetLogoStatus`

Type: plist boolean

Default value: false

Description: Reset BGRT table `Displayed` status field to false.

This works around firmwares that provide BGRT table but fail to handle screen updates afterwards.

5 DeviceProperties

5.1 Introduction

Device configuration is provided to macOS with a dedicated buffer, called `EfiDevicePropertyDatabase`. This buffer is a serialised map of `DevicePaths` to a map of property names and their values.

Property data can be debugged with `gfxutil`. To obtain current property data use the following command in macOS:

```
ioreg -lw0 -p IODeviceTree -n efi -r -x | grep device-properties |
sed 's/.*<\/;s/>.*//' > /tmp/device-properties.hex &&
gfxutil /tmp/device-properties.hex /tmp/device-properties.plist &&
cat /tmp/device-properties.plist
```

5.2 Properties

1. Add

Type: `plist dict`

Description: Sets device properties from a map (`plist dict`) of device paths to a map (`plist dict`) of variable names and their values in `plist metadata` format. Device paths must be provided in canonic string format (e.g. `PciRoot(0x0)/Pci(0x1,0x0)/Pci(0x0,0x0)`). Properties will only be set if not present and not blocked.

Note: Currently properties may only be (formerly) added by the original driver, so unless a separate driver was installed, there is no reason to block the variables.

2. Block

Type: `plist dict`

Description: Removes device properties from a map (`plist dict`) of device paths to an array (`plist array`) of variable names in `plist string` format.

5.3 Common Properties

Some known properties include:

- `device-id`
User-specified device identifier used for I/O Kit matching. Has 4 byte data type.
- `vendor-id`
User-specified vendor identifier used for I/O Kit matching. Has 4 byte data type.
- `AAPL,ig-platform-id`
Intel GPU framebuffer identifier used for framebuffer selection on Ivy Bridge and newer. Has 4 byte data type.
- `AAPL,snb-platform-id`
Intel GPU framebuffer identifier used for framebuffer selection on Sandy Bridge. Has 4 byte data type.
- `layout-id`
Audio layout used for AppleHDA layout selection. Has 4 byte data type.

6 Kernel

6.1 Introduction

This section allows to apply different kinds of kernelspace modifications on Apple Kernel (XNU). The modifications currently provide driver (kext) injection, kernel and driver patching, and driver blocking.

6.2 Properties

1. Add

Type: plist array

Default value: Empty

Description: Load selected kernel drivers from `OC/Kexts` directory.

Designed to be filled with `plist dict` values, describing each driver. See Add Properties section below. Kernel driver load order follows the item order in the array, thus the dependencies should be written prior to their consumers.

2. Block

Type: plist array

Default value: Empty

Description: Remove selected kernel drivers from prelinked kernel.

Designed to be filled with `plist dictionary` values, describing each blocked driver. See Block Properties section below.

3. Patch

Type: plist array

Default value: Empty

Description: Perform binary patches in kernel and drivers prior to driver addition and removal.

Designed to be filled with `plist dictionary` values, describing each patch. See Patch Properties section below.

4. Quirks

Type: plist dict

Description: Apply individual kernel and driver quirks described in Quirks Properties section below.

6.3 Add Properties

1. BundlePath

Type: plist string

Default value: Empty string

Description: Kext bundle path (e.g. `Lilu.kext` or `MyKext.kext/Contents/PlugIns/MySubKext.kext`).

2. Comment

Type: plist string

Default value: Empty string

Description: Arbitrary ASCII string used to provide human readable reference for the entry. It is implementation defined whether this value is used.

3. Enabled

Type: plist boolean

Default value: false

Description: This kernel driver will not be added unless set to `true`.

4. ExecutablePath

Type: plist string

Default value: Empty string

Description: Kext executable path relative to bundle (e.g. `Contents/MacOS/Lilu`).

5. MatchKernel

Type: plist string

Default value: Empty string

Description: Blocks kernel driver on selected macOS version only. The selection happens based on prefix match with the kernel version, i.e. 16.7.0 will match macOS 10.12.6 and 16. will match any macOS 10.12.x version.

6. PlistPath

Type: plist string

Default value: Empty string

Description: Kext Info.plist path relative to bundle (e.g. Contents/Info.plist).

6.4 Block Properties

1. Comment

Type: plist string

Default value: Empty string

Description: Arbitrary ASCII string used to provide human readable reference for the entry. It is implementation defined whether this value is used.

2. Enabled

Type: plist boolean

Default value: false

Description: This kernel driver will not be blocked unless set to true.

3. Identifier

Type: plist string

Default value: Empty string

Description: Kext bundle identifier (e.g. com.apple.driver.AppleTyMCEDriver).

4. MatchKernel

Type: plist string

Default value: Empty string

Description: Blocks kernel driver on selected macOS version only. The selection happens based on prefix match with the kernel version, i.e. 16.7.0 will match macOS 10.12.6 and 16. will match any macOS 10.12.x version.

6.5 Patch Properties

1. Base

Type: plist string

Default value: Empty string

Description: Selects symbol-matched base for patch lookup (or immediate replacement) by obtaining the address of provided symbol name. Can be set to empty string to be ignored.

2. Comment

Type: plist string

Default value: Empty string

Description: Arbitrary ASCII string used to provide human readable reference for the entry. It is implementation defined whether this value is used.

3. Count

Type: plist integer

Default value: 0

Description: Number of patch occurrences to apply. 0 applies the patch to all occurrences found.

4. Enabled

Type: plist boolean

Default value: false

Description: This kernel patch will not be used unless set to true.

5. Find

Type: plist data

Default value: Empty data

Description: Data to find. Can be set to empty for immediate replacement at Base. Must equal to Replace in size otherwise.

6. Identifier
 - Type:** plist string
 - Default value:** Empty string
 - Description:** Kext bundle identifier (e.g. `com.apple.driver.AppleHDA`) or `kernel` for kernel patch.
7. Limit
 - Type:** plist integer
 - Default value:** 0
 - Description:** Maximum number of bytes to search for. Can be set to 0 to look through the whole kext or kernel.
8. Mask
 - Type:** plist data
 - Default value:** Empty data
 - Description:** Data bitwise mask used during find comparison. Allows fuzzy search by ignoring not masked (set to zero) bits. Can be set to empty data to be ignored. Must equal to **Replace** in size otherwise.
9. MatchKernel
 - Type:** plist string
 - Default value:** Empty string
 - Description:** Adds kernel driver to selected macOS version only. The selection happens based on prefix match with the kernel version, i.e. `16.7.0` will match macOS 10.12.6 and `16.` will match any macOS 10.12.x version.
10. Replace
 - Type:** plist data
 - Default value:** Empty data
 - Description:** Replacement data of one or more bytes.
11. ReplaceMask
 - Type:** plist data
 - Default value:** Empty data
 - Description:** Data bitwise mask used during replacement. Allows fuzzy replacement by updating masked (set to non-zero) bits. Can be set to empty data to be ignored. Must equal to **Replace** in size otherwise.
12. Skip
 - Type:** plist integer
 - Default value:** 0
 - Description:** Number of found occurrences to be skipped before replacement is done.

6.6 Quirks Properties

1. AppleCpuPmCfgLock
 - Type:** plist boolean
 - Default value:** false
 - Description:** Disables `PKG_CST_CONFIG_CONTROL (0xE2)` MSR modification in `AppleIntelCPUPowerManagement.kext`, commonly causing early kernel panic, when it is locked from writing.
 - Note:* This option should avoided whenever possible. Modern firmwares provide **CFG Lock** setting, disabling which is much cleaner. More details about the issue can be found in `VerifyMsrE2` notes.
2. AppleXcpmCfgLock
 - Type:** plist boolean
 - Default value:** false
 - Description:** Disables `PKG_CST_CONFIG_CONTROL (0xE2)` MSR modification in XNU kernel, commonly causing early kernel panic, when it is locked from writing (XCPM power management).
 - Note:* This option should avoided whenever possible. Modern firmwares provide **CFG Lock** setting, disabling which is much cleaner. More details about the issue can be found in `VerifyMsrE2` notes.
3. ExternalDiskIcons
 - Type:** plist boolean
 - Default value:** false
 - Description:** Apply icon type patches to `IOAHCIPort.kext` to force internal disk icons for all AHCI disks.

Note: This option should be avoided whenever possible. Modern firmwares usually have compatible AHCI controllers.

4. ThirdPartyTrim

Type: plist boolean

Default value: false

Description: Patch IOAHCIFamily.kext to force TRIM command support on AHCI SSDs.

Note: This option should be avoided whenever possible. NVMe SSDs are compatible without the change. For AHCI SSDs on modern macOS version there is a dedicated built-in utility called `trimforce`.

5. XhciPortLimit

Type: plist boolean

Default value: false

Description: Patch various kexts (AppleUSBXHCI.kext, AppleUSBXHCIPCI.kext, IOUSBHostFamily.kext) to remove USB port count limit of 15 ports.

Note: This option should be avoided whenever possible. USB port limit is imposed by the amount of used bits in locationID format and there is no possible way to work around this without heavy OS modification. The only valid solution is to limit the amount of used ports to 15 (discarding some). More details can be found on AppleLife.ru.

7 Misc

7.1 Introduction

This section contains miscellaneous configuration entries for OpenCore behaviour that does not go to any other sections

7.2 Properties

1. **Boot**
Type: plist dict
Description: Apply boot configuration described in Boot Properties section below.
2. **Debug**
Type: plist dict
Description: Apply debug configuration described in Debug Properties section below.
3. **Security**
Type: plist dict
Description: Apply security configuration described in Security Properties section below.

7.3 Boot Properties

1. **ConsoleMode**
Type: plist string
Default value: Empty string
Description: Sets console output mode as specified with the WxH (e.g. 80x24) formatted string. Set to empty string not to change console mode. Set to **Max** to try to use largest available console mode.
2. **ConsoleBehaviourOs**
Type: plist string
Default value: Empty string
Description: Set console control behaviour upon operating system load.

Console control is a legacy protocol used for switching between text and graphics screen output. Some firmwares do not provide it, yet select operating systems require its presence, which is what **ProvideConsoleControl** UEFI quirk is for.

When console control is available, OpenCore can be made console control aware, and and set different modes for the operating system booter (**ConsoleBehaviourOs**), which normally runs in graphics mode, and its own user interface (**ConsoleBehaviourUi**), which normally runs in text mode. Possible behaviours, set as values of these options, include:

- Empty string — Do not modify console control mode.
- **Text** — Switch to text mode.
- **Graphics** — Switch to graphics mode.
- **ForceText** — Switch to text mode and preserve it (requires **ProvideConsoleControl**).
- **ForceGraphics** — Switch to graphics mode and preserve it (require **ProvideConsoleControl**).

Hints:

- Unless empty works, firstly try to set **ConsoleBehaviourOs** to **Graphics** and **ConsoleBehaviourUi** to **Text**.
- On APTIO IV (Haswell and earlier) it is usually enough to have **ConsoleBehaviourOs** set to **Graphics** and **ConsoleBehaviourUi** set to **ForceText** to avoid visual glitches.
- On APTIO V (Broadwell and newer) **ConsoleBehaviourOs** set to **ForceGraphics** and **ConsoleBehaviourUi** set to **Text** usually works best.

Note: **IgnoreTextInGraphics** may need to be enabled for select firmware implementations.

3. **ConsoleBehaviourUi**
Type: plist string
Default value: Empty string
Description: Set console control behaviour upon OpenCore user interface load. Refer to **ConsoleBehaviourOs** description for details.

4. HideSelf

Type: plist boolean
Default value: false
Description: Hides own boot entry from boot picker. This may potentially hide other entries, for instance, when another UEFI OS is installed on the same volume and driver boot is used.
5. Resolution

Type: plist string
Default value: Empty string
Description: Sets console output screen resolution.

 - Set to WxH@Bpp (e.g. 1920x1080@32) WxH (e.g. 1920x1080) formatted string to request custom resolution from GOP if available.
 - Set to empty string not to change screen resolution.
 - Set to Max to try to use largest available screen resolution.

On HiDPI screens APPLE_VENDOR_VARIABLE_GUID UIscale NVRAM variable may need to be set to 02 to enable HiDPI scaling in FileVault 2 UEFI password interface and boot screen logo. Refer to Recommended Variables section for more details.

Note: This will fail when console handle has no GOP protocol. When the firmware does not provide it, it can be added with ProvideConsoleGop UEFI quirk set to true.
6. ShowPicker

Type: plist boolean
Default value: false
Description: Show simple boot picker to allow boot entry selection.
7. Timeout

Type: plist integer, 32 bit
Default value: 0
Description: Timeout in seconds in boot picker before automatic booting of the default boot entry.

7.4 Debug Properties

1. DisableWatchDog

Type: plist boolean
Default value: NO
Description: Select firmwares may not succeed in quickly booting the operating system, especially in debug mode, which results in watch dog timer aborting the process. This option turns off watch dog timer.
2. DisplayDelay

Type: plist integer
Default value: 0
Description: Delay in microseconds performed after every printed line visible onscreen (i.e. console).
3. DisplayLevel

Type: plist integer, 64 bit
Default value: 0
Description: EDK II debug level bitmask (sum) showed onscreen. Unless **Target** enables console (onscreen) printing, onscreen debug output will not be visible. The following levels are supported (discover more in DebugLib.h):

 - 0x00000002 — DEBUG_WARN in DEBUG, NOOPT, RELEASE.
 - 0x00000040 — DEBUG_INFO in DEBUG, NOOPT.
 - 0x00400000 — DEBUG_VERBOSE in custom builds.
 - 0x80000000 — DEBUG_ERROR in DEBUG, NOOPT, RELEASE.
4. Target

Type: plist integer
Default value: 0
Description: A bitmask (sum) of enabled logging targets. By default all the logging output is hidden, so this option is required to be set when debugging is necessary.

The following logging targets are supported:

- 0x01 — Enable logging, otherwise all log is discarded.
- 0x02 — Enable basic console (onscreen) logging.
- 0x04 — Enable logging to Data Hub.
- 0x08 — Enable serial port logging.
- 0x10 — Enable UEFI variable logging.
- 0x20 — Enable non-volatile UEFI variable logging.
- 0x40 — Enable logging to file.

Console logging prints less than all the other variants. Depending on the build type (`RELEASE`, `DEBUG`, or `NOOPT`) different amount of logging may be read (from least to most).

Data Hub log will not log kernel and kext patches. To obtain Data Hub log use the following command in macOS:

```
ioreg -lw0 -p IODeviceTree | grep boot-log | sort | sed 's/.*<\(.*\)>.*\/\1/' | xxd -r -p
```

UEFI variable log does not include some messages and has no performance data. For safety reasons log size is limited to 32 kilobytes. Some firmwares may truncate it much earlier or drop completely if they have no memory. Using non-volatile flag will write the log to NVRAM flash after every printed line. To obtain UEFI variable log use the following command in macOS:

```
nvram 4D1FDA02-38C7-4A6A-9CC6-4BCCA8B30102:boot-log |  
awk '{gsub(/%0d%0a%00/, "");gsub(/%0d%0a/, "\n")}'
```

Warning: Some firmwares are reported to have broken NVRAM garbage collection. This means that they may not be able to always free space after variable deletion. Do not use non-volatile NVRAM logging without extra need on such devices.

While OpenCore boot log already contains basic version information with build type and date, this data may also be found in NVRAM in `opencore-version` variable even with boot log disabled.

File logging will create a file named `opencore.log` at EFI volume root with log contents. Please be warned that some file system drivers present in firmwares are not reliable, and may corrupt data when writing files through UEFI. Log is attempted to be written in the safest manner, and thus is very slow. Ensure that `DisableWatchDog` is set to `true` when you use a slow drive.

7.5 Security Properties

1. ExposeSensitiveData

Type: plist integer

Default value: 2

Description: Sensitive data exposure bitmask (sum) to operating system.

- 0x01 — Expose printable booter path as an UEFI variable.
- 0x02 — Expose OpenCore version as an UEFI variable.

Exposed booter path points to OpenCore.efi or its booter depending on the load order. To obtain booter path use the following command in macOS:

```
nvram 4D1FDA02-38C7-4A6A-9CC6-4BCCA8B30102:booter-path
```

To use booter path for mounting booter volume use the following command in macOS:

```
u=$(nvram 4D1FDA02-38C7-4A6A-9CC6-4BCCA8B30102:booter-path | sed 's/.*GPT,\([\^\,]*\),.*\/\1/'); \  
if [ "$u" != "" ]; then sudo diskutil mount $u ; fi
```

To obtain OpenCore version use the following command in macOS:

```
nvram 4D1FDA02-38C7-4A6A-9CC6-4BCCA8B30102:opencore-version
```

2. HaltLevel

Type: plist integer, 64 bit

Default value: 0x80000000 (DEBUG_ERROR)

Description: EDK II debug level bitmask (sum) causing CPU to halt (stop execution) after obtaining a message of HaltLevel. Possible values match DisplayLevel values.

3. RequireSignature

Type: plist boolean

Default value: true

Description: Require vault.sig signature file for vault.plist in OC directory.

This file should contain a raw 256 byte RSA-2048 signature from SHA-256 hash of vault.plist. The signature is verified against the public key embedded into OpenCore.efi.

To embed the public key you should do either of the following:

- Provide public key during the OpenCore.efi compilation in OpenCoreVault.c file.
- Binary patch OpenCore.efi replacing zeroes with the public key between =BEGIN OC VAULT= and ==END OC VAULT== ASCII markers.

RSA public key 520 byte format description can be found in Chromium OS documentation. To convert public key from X.509 certificate or from PEM file use RsaTool.

Note: vault.sig is used regardless of this option when public key is embedded into OpenCore.efi. Setting it to true will only ensure configuration sanity, and abort the boot process when public key is not set but was supposed to be used for verification.

4. RequireVault

Type: plist boolean

Default value: true

Description: Require vault.plist file present in OC directory.

This file should contain SHA-256 hashes for all files used by OpenCore. Presence of this file is highly recommended to ensure that unintentional file modifications (including filesystem corruption) do not happen unnoticed. To create this file automatically use create_vault.sh script.

Regardless of the underlying filesystem, path name and case must match between config.plist and vault.plist.

Note: vault.plist is tried to be read regardless of the value of this option, but setting it to true will ensure configuration sanity, and abort the boot process.

The complete set of commands to:

- Create vault.plist.
- Create a new RSA key (always do this to avoid loading old configuration).
- Embed RSA key into OpenCore.efi.
- Create vault.sig.

Can look as follows:

```
cd /Volumes/EFI/EFI/OC
/path/to/create_vault.sh .
/path/to/RsaTool -sign vault.plist vault.sig vault.pub
off=$((($(strings -a -t d OpenCore.efi | grep "=BEGIN OC VAULT=" | cut -f1 -d' ')+16))
dd of=OpenCore.efi if=vault.pub bs=1 seek=$off count=520 conv=notrunc
rm vault.pub
```

Note: While it may appear obvious, but you have to use an external method to verify OpenCore.efi and B00Tx64.efi for secure boot path. For this you are recommended to at least enable UEFI SecureBoot with a custom certificate, and sign OpenCore.efi and B00Tx64.efi with your custom key. More details on customising secure boot on modern firmwares can be found in Taming UEFI SecureBoot paper (in Russian).

8 NVRAM

8.1 Introduction

Has `plist dict` type and allows to set volatile UEFI variables commonly referred as NVRAM variables. Refer to `man nvram` for more details. macOS extensively uses NVRAM variables for OS — Bootloader — Firmware intercommunication, and thus supplying several NVRAM is required for proper macOS functioning.

Each NVRAM variable consists of its name, value, attributes (refer to UEFI specification), and its GUID, representing which ‘section’ NVRAM variable belongs to. macOS uses several GUIDs, including but not limited to:

- 4D1EDE05-38C7-4A6A-9CC6-4BCCA8B38C14 (APPLE_VENDOR_VARIABLE_GUID)
- 7C436110-AB2A-4BBB-A880-FE41995C9F82 (APPLE_BOOT_VARIABLE_GUID)
- 8BE4DF61-93CA-11D2-AA0D-00E098032B8C (EFI_GLOBAL_VARIABLE_GUID)
- 4D1FDA02-38C7-4A6A-9CC6-4BCCA8B30102 (OC_VENDOR_VARIABLE_GUID)

Note: Some of the variables may be added by PlatformNVRAM or Generic subsections of PlatformInfo section. Please ensure that variables of this section never collide with them, as behaviour is undefined otherwise.

8.2 Properties

1. Add

Type: `plist dict`

Description: Sets NVRAM variables from a map (`plist dict`) of GUIDs to a map (`plist dict`) of variable names and their values in `plist metadata` format. GUIDs must be provided in canonic string format in upper or lower case (e.g. 8BE4DF61-93CA-11D2-AA0D-00E098032B8C).

Created variables get `EFI_VARIABLE_BOOTSERVICE_ACCESS` and `EFI_VARIABLE_RUNTIME_ACCESS` attributes set. Variables will only be set if not present and not blocked. To overwrite a variable add it to `Block` section. This approach enables to provide default values till the operating system takes the lead.

Note: If `plist` key does not conform to GUID format, behaviour is undefined.

2. Block

Type: `plist dict`

Description: Removes NVRAM variables from a map (`plist dict`) of GUIDs to an array (`plist array`) of variable names in `plist string` format.

To read NVRAM variable value from macOS one could use `nvram` by concatenating variable GUID and name separated by `:` symbol. For example, `nvram 7C436110-AB2A-4BBB-A880-FE41995C9F82:boot-args`.

A continuously updated variable list can be found in a corresponding document: NVRAM Variables.

8.3 Mandatory Variables

Warning: These variables may be added by PlatformNVRAM or Generic subsections of PlatformInfo section. Using PlatformInfo is the recommend way of setting these variables.

The following variables are mandatory for macOS functioning:

- 4D1EDE05-38C7-4A6A-9CC6-4BCCA8B38C14:FirmwareFeatures
32-bit FirmwareFeatures. Present on all Macs to avoid extra parsing of SMBIOS tables
- 4D1EDE05-38C7-4A6A-9CC6-4BCCA8B38C14:FirmwareFeaturesMask
32-bit FirmwareFeaturesMask. Present on all Macs to avoid extra parsing of SMBIOS tables.
- 4D1EDE05-38C7-4A6A-9CC6-4BCCA8B38C14:MLB
BoardSerialNumber. Present on newer Macs (2013+ at least) to avoid extra parsing of SMBIOS tables, especially in boot.efi.
- 4D1EDE05-38C7-4A6A-9CC6-4BCCA8B38C14:ROM
Primary network adapter MAC address or replacement value. Present on newer Macs (2013+ at least) to avoid accessing special memory region, especially in boot.efi.

8.4 Recommended Variables

The following variables are recommended for faster startup or other improvements:

- `7C436110-AB2A-4BBB-A880-FE41995C9F82:csr-active-config`
32-bit System Integrity Protection bitmask. Declared in XNU source code in `csr.h`.
- `4D1EDE05-38C7-4A6A-9CC6-4BCCA8B38C14:ExtendedFirmwareFeatures`
Combined `FirmwareFeatures` and `ExtendedFirmwareFeatures`. Present on newer Macs to avoid extra parsing of SMBIOS tables
- `4D1EDE05-38C7-4A6A-9CC6-4BCCA8B38C14:ExtendedFirmwareFeaturesMask`
Combined `FirmwareFeaturesMask` and `ExtendedFirmwareFeaturesMask`. Present on newer Macs to avoid extra parsing of SMBIOS tables.
- `4D1EDE05-38C7-4A6A-9CC6-4BCCA8B38C14:HW_BID`
Hardware BoardProduct (e.g. `Mac-35C1E88140C3E6CF`). Not present on real Macs, but used to avoid extra parsing of SMBIOS tables, especially in `boot.efi`.
- `4D1EDE05-38C7-4A6A-9CC6-4BCCA8B38C14:HW_MLB`
Hardware BoardSerialNumber. Override for MLB. Present on newer Macs (2013+ at least).
- `4D1EDE05-38C7-4A6A-9CC6-4BCCA8B38C14:HW_ROM`
Hardware ROM. Override for ROM. Present on newer Macs (2013+ at least).
- `7C436110-AB2A-4BBB-A880-FE41995C9F82:prev-lang:kbd`
ASCII string defining default keyboard layout. Format is `lang-COUNTRY:keyboard`, e.g. `ru-RU:19456` for Mac keyboard. Also accepts short forms: `ru:19456` or `ru:0`. Full decoded list of keyboards in `AppleKeyboardLayouts-L.dat` can be found on AppleLife.
- `7C436110-AB2A-4BBB-A880-FE41995C9F82:security-mode`
ASCII string defining FireWire security mode. Legacy, can be found in `IOFireWireFamily` source code in `IOFireWireController.cpp`. It is recommended not to set this variable, which may speedup system startup. Setting to `full` is equivalent to not setting the variable and `none` disables FireWire security.
- `4D1EDE05-38C7-4A6A-9CC6-4BCCA8B38C14:UIScale`
8-bit integer defining `boot.efi` user interface scaling. Should be 1 for normal screens and 2 for HDPI screens.

8.5 Other Variables

The following variables may be useful for certain configurations or troubleshooting:

- `7C436110-AB2A-4BBB-A880-FE41995C9F82:boot-args`
Kernel arguments, used to pass configuration to Apple kernel and drivers. There are many arguments, which may be found by looking for the use of `PE_parse_boot_argn` function in the kernel or driver code. Some of the known boot arguments include:
 - `acpi_layer=0xFFFFFFFF`
 - `acpi_level=0xFFFF5F` (implies `ACPI_ALL_COMPONENTS`)
 - `cpus=VALUE`
 - `debug=VALUE`
 - `io=VALUE`
 - `keepsyms=1`
 - `kextlog=VALUE`
 - `nvda_drv=1`
 - `slide=VALUE`
 - `-nehalem_error_disable`
 - `-no_compat_check`
 - `-s`
 - `-v`
 - `-x`
- `7C436110-AB2A-4BBB-A880-FE41995C9F82:bootercfg`
Booter arguments, similar to `boot-args` but for `boot.efi`. Accepts a set of arguments, which are hexadecimal 64-bit values with or without `0x` prefix primarily for logging control:
 - `log=VALUE`
 - * 1 — `AppleLoggingConOutOrErrSet/AppleLoggingConOutOrErrPrint` (classical `ConOut/StdErr`)
 - * 2 — `AppleLoggingStdErrSet/AppleLoggingStdErrPrint` (`StdErr` or serial?)
 - * 4 — `AppleLoggingFileSet/AppleLoggingFilePrint` (`BOOTER.LOG/BOOTER.OLD` file on EFI partition)

- **debug=VALUE**
 - * 1 — enables print something to `BOOTER.LOG` (stripped code implies there may be a crash)
 - * 2 — enables perf logging to `/efi/debug-log` in the device tree
 - * 4 — enables timestamp printing for styled printf calls
- **level=VALUE** — Verbosity level of `DEBUG` output. Everything but `0x80000000` is stripped from the binary, and this is the default value.
- **kc-read-size=VALUE** — Chunk size used for buffered I/O from network or disk for prelinkedkernel reading and related. Set to 1MB (`0x100000`) by default, can be tuned for faster booting.
- `7C436110-AB2A-4BBB-A880-FE41995C9F82:bootercfg-once`
Booter arguments override removed after first launch. Otherwise equivalent to `bootercfg`.
- `7C436110-AB2A-4BBB-A880-FE41995C9F82:fmm-computer-name`
- `7C436110-AB2A-4BBB-A880-FE41995C9F82:nvda_drv`

9 PlatformInfo

Platform information is comprised of several identification fields generated or filled manually to be compatible with macOS services. The base part of the configuration may be obtained from `MacInfoPkg` package, which itself generates a set of interfaces based on a database in YAML format. These fields are written to three select destinations:

- SMBIOS
- Data Hub
- NVRAM

Most of the fields specify the overrides in SMBIOS, and their field names conform to EDK2 `SmBios.h` header file. However, several important fields reside in Data Hub and NVRAM. Some of the values can be found in more than one field and/or destination, so there are two ways to control their update process: manual, where one specifies all the values (the default), and semi-automatic, where (`Automatic`) only select values are specified, and later used for system configuration.

9.1 Properties

1. `Automatic`

Type: plist boolean

Default value: false

Description: Generate PlatformInfo based on `Generic` section instead of using values from `DataHub`, `NVRAM`, and `SMBIOS` sections.

Enabling this option is useful when `Generic` section is flexible enough. When enabled `SMBIOS`, `DataHub`, and `PlatformNVRAM` data is unused.

2. `UpdateDataHub`

Type: plist boolean

Default value: false

Description: Update DataHub fields. These fields are read from `Generic` or `DataHub` sections depending on `Automatic` value.

3. `UpdateNVRAM`

Type: plist boolean

Default value: false

Description: Update NVRAM fields related to platform information.

These fields are read from `Generic` or `PlatformNVRAM` sections depending on `Automatic` value. All the other fields are to be specified with `NVRAM` section.

If `UpdateNVRAM` is set to `false` the aforementioned variables can be updated with `NVRAM` section. If `UpdateNVRAM` is set to `true` the behaviour is undefined when any of the fields are present in `NVRAM` section.

4. `UpdateSMBIOS`

Type: plist boolean

Default value: false

Description: Update SMBIOS fields. These fields are read from `Generic` or `SMBIOS` sections depending on `Automatic` value.

5. `UpdateSMBIOSMode`

Type: plist string

Default value: Auto

Description: Update SMBIOS fields approach:

- `Auto` — Overwrite if new size is \leq than the page-aligned original and there are no issues with legacy region unlock. `Create` otherwise.
- `Create` — Replace the tables with newly allocated `EfiReservedMemoryType` at `AllocateMaxAddress` without any fallbacks.
- `Overwrite` — Overwrite existing `gEfiSmbiosTableGuid` and `gEfiSmbiosTable3Guid` data if it fits new size. Abort with unspecified state otherwise.
- `Custom` — Write first SMBIOS table (`gEfiSmbiosTableGuid`) to `gOcCustomSmbiosTableGuid` to workaround firmwares overwriting SMBIOS contents at `ExitBootServices`. Otherwise equivalent to `Create`. Requires

patching AppleSmbios.kext and AppleACPIPlatform.kext to read from another GUID: "EB9D2D31" -> "EB9D2D35" (in ASCII).

6. Generic
Type: plist dictionary
Optional: When Automatic is false
Description: Update all fields. This section is read only when Automatic is active.
7. DataHub
Type: plist dictionary
Optional: When Automatic is true
Description: Update Data Hub fields. This section is read only when Automatic is not active.
8. PlatformNVRAM
Type: plist dictionary
Optional: When Automatic is true
Description: Update platform NVRAM fields. This section is read only when Automatic is not active.
9. SMBIOS
Type: plist dictionary
Optional: When Automatic is true
Description: Update SMBIOS fields. This section is read only when Automatic is not active.

9.2 Generic Properties

1. SpoofVendor
Type: plist boolean
Default value: false
Description: Sets SMBIOS vendor fields to Acidanthera.

It is dangerous to use Apple in SMBIOS vendor fields for reasons given in SystemManufacturer description. However, certain firmwares may not provide valid values otherwise, which could break some software.

2. SystemProductName
Type: plist string
Default value: MacPro6,1
Description: Refer to SMBIOS SystemProductName.
3. SystemSerialNumber
Type: plist string
Default value: OPENCORE_SN1
Description: Refer to SMBIOS SystemSerialNumber.
4. SystemUUID
Type: plist string, GUID
Default value: OEM specified
Description: Refer to SMBIOS SystemUUID.
5. MLB
Type: plist string
Default value: OPENCORE_MLB_SN11
Description: Refer to SMBIOS BoardSerialNumber.
6. ROM
Type: plist data, 6 bytes
Default value: all zero
Description: Refer to 4D1EDE05-38C7-4A6A-9CC6-4BCCA8B38C14:ROM.

9.3 DataHub Properties

1. PlatformName
Type: plist string

- Default value:** Not installed
Description: Sets name in gEfiMiscSubClassGuid. Value found on Macs is platform in ASCII.
2. SystemProductName
Type: plist string
Default value: Not installed
Description: Sets Model in gEfiMiscSubClassGuid. Value found on Macs is equal to SMBIOS SystemProductName in Unicode.
 3. SystemSerialNumber
Type: plist string
Default value: Not installed
Description: Sets SystemSerialNumber in gEfiMiscSubClassGuid. Value found on Macs is equal to SMBIOS SystemSerialNumber in Unicode.
 4. SystemUUID
Type: plist string, GUID
Default value: Not installed
Description: Sets system-id in gEfiMiscSubClassGuid. Value found on Macs is equal to SMBIOS SystemUUID.
 5. BoardProduct
Type: plist string
Default value: Not installed
Description: Sets board-id in gEfiMiscSubClassGuid. Value found on Macs is equal to SMBIOS BoardProduct in ASCII.
 6. BoardRevision
Type: plist data, 1 byte
Default value: 0
Description: Sets board-rev in gEfiMiscSubClassGuid. Value found on Macs seems to correspond to internal board revision (e.g. 01).
 7. StartupPowerEvents
Type: plist integer, 64-bit
Default value: 0
Description: Sets StartupPowerEvents in gEfiMiscSubClassGuid. Value found on Macs is power management state bitmask, normally 0. Known bits read by X86PlatformPlugin.kext:
 - 0x00000001 — Shutdown cause was a PWROK event (Same as GEN_PMCON_2 bit 0)
 - 0x00000002 — Shutdown cause was a SYS_PWROK event (Same as GEN_PMCON_2 bit 1)
 - 0x00000004 — Shutdown cause was a THRMTRIP# event (Same as GEN_PMCON_2 bit 3)
 - 0x00000008 — Rebooted due to a SYS_RESET# event (Same as GEN_PMCON_2 bit 4)
 - 0x00000010 — Power Failure (Same as GEN_PMCON_3 bit 1 PWR_FLR)
 - 0x00000020 — Loss of RTC Well Power (Same as GEN_PMCON_3 bit 2 RTC_PWR_STS)
 - 0x00000040 — General Reset Status (Same as GEN_PMCON_3 bit 9 GEN_RST_STS)
 - 0xfffff80 — SUS Well Power Loss (Same as GEN_PMCON_3 bit 14)
 - 0x00010000 — Wake cause was a ME Wake event (Same as PRSTS bit 0, ME_WAKE_STS)
 - 0x00020000 — Cold Reboot was ME Induced event (Same as PRSTS bit 1 ME_HRST_COLD_STS)
 - 0x00040000 — Warm Reboot was ME Induced event (Same as PRSTS bit 2 ME_HRST_WARM_STS)
 - 0x00080000 — Shutdown was ME Induced event (Same as PRSTS bit 3 ME_HOST_PWRDN)
 - 0x00100000 — Global reset ME Watchdog Timer event (Same as PRSTS bit 6)
 - 0x00200000 — Global reset PowerManagement Watchdog Timer event (Same as PRSTS bit 15)
 8. InitialTSC
Type: plist integer, 64-bit
Default value: 0
Description: Sets InitialTSC in gEfiProcessorSubClassGuid. Sets initial TSC value, normally 0.
 9. FSBFrequency
Type: plist integer, 64-bit
Default value: Automatic
Description: Sets FSBFrequency in gEfiProcessorSubClassGuid. Sets CPU FSB frequency.

10. **ARTFrequency**
Type: plist integer, 64-bit
Default value: Not installed
Description: Sets ARTFrequency in gEfiProcessorSubClassGuid. Sets CPU ART frequency, Skylake and newer.
11. **DevicePathsSupported**
Type: plist data, 1 byte
Default value: Not installed
Description: Sets DevicePathsSupported in gEfiMiscSubClassGuid. Must be set to 01 for AppleACPIPlatform.kext to append SATA device paths to Boot#### and efi-boot-device-data variables. Set to 01 on all modern Macs.
12. **SmcRevision**
Type: plist data, 6 bytes
Default value: Not installed
Description: Sets REV in gEfiMiscSubClassGuid. Custom property read by VirtualSMC or FakeSMC to generate SMC REV key.
13. **SmcBranch**
Type: plist data, 8 bytes
Default value: Not installed
Description: Sets RBr in gEfiMiscSubClassGuid. Custom property read by VirtualSMC or FakeSMC to generate SMC RBr key.
14. **SmcPlatform**
Type: plist data, 8 bytes
Default value: Not installed
Description: Sets RPlt in gEfiMiscSubClassGuid. Custom property read by VirtualSMC or FakeSMC to generate SMC RPlt key.

9.4 PlatformNVRAM Properties

1. **BID**
Type: plist string
Default value: Not installed
Description: Specifies the value of NVRAM variable 4D1EDE05-38C7-4A6A-9CC6-4BCCA8B38C14:HW_BID.
2. **ROM**
Type: plist data, 6 bytes
Default value: Not installed
Description: Specifies the values of NVRAM variables 4D1EDE05-38C7-4A6A-9CC6-4BCCA8B38C14:HW_ROM and 4D1EDE05-38C7-4A6A-9CC6-4BCCA8B38C14:ROM.
3. **MLB**
Type: plist string
Default value: Not installed
Description: Specifies the values of NVRAM variables 4D1EDE05-38C7-4A6A-9CC6-4BCCA8B38C14:HW_MLB and 4D1EDE05-38C7-4A6A-9CC6-4BCCA8B38C14:MLB.
4. **FirmwareFeatures**
Type: plist data, 8 bytes
Default value: Not installed
Description: This variable comes in pair with FirmwareFeaturesMask. Specifies the values of NVRAM variables:
 - 4D1EDE05-38C7-4A6A-9CC6-4BCCA8B38C14:FirmwareFeatures
 - 4D1EDE05-38C7-4A6A-9CC6-4BCCA8B38C14:ExtendedFirmwareFeatures
5. **FirmwareFeaturesMask**
Type: plist data, 8 bytes
Default value: Not installed
Description: This variable comes in pair with FirmwareFeatures. Specifies the values of NVRAM variables:

- 4D1EDE05-38C7-4A6A-9CC6-4BCCA8B38C14:FirmwareFeaturesMask
- 4D1EDE05-38C7-4A6A-9CC6-4BCCA8B38C14:ExtendedFirmwareFeaturesMask

9.5 SMBIOS Properties

1. BIOSVendor

Type: plist string

Default value: OEM specified

SMBIOS: BIOS Information (Type 0) — Vendor

Description: BIOS Vendor. All rules of `SystemManufacturer` do apply.

2. BIOSVersion

Type: plist string

Default value: OEM specified

SMBIOS: BIOS Information (Type 0) — BIOS Version

Description: Firmware version. This value gets updated and takes part in update delivery configuration and macOS version compatibility. This value could look like `MM71.88Z.0234.B00.1809171422` in older firmwares, and is described in `BiosId.h`. In newer firmwares it should look like `236.0.0.0.0` or `220.230.16.0.0` (`iBridge: 16.16.2542.0.0,0`). `iBridge` version is read from `BridgeOSVersion` variable, and is only present on macs with T2.

Apple ROM Version

```

BIOS ID:      MBP151.88Z.F000.B00.1811142212
Model:       MBP151
EFI Version:  220.230.16.0.0
Built by:    root@quinoa
Date:       Wed Nov 14 22:12:53 2018
Revision:   220.230.16 (B&I)
ROM Version: F000_B00
Build Type:  Official Build, RELEASE
Compiler:   Apple LLVM version 10.0.0 (clang-1000.2.42)
UUID:      E5D1475B-29FF-32BA-8552-682622BA42E1
UUID:      151B0907-10F9-3271-87CD-4BF5DBECACF5

```

3. BIOSReleaseDate

Type: plist string

Default value: OEM specified

SMBIOS: BIOS Information (Type 0) — BIOS Release Date

Description: Firmware release date. Similar to `BIOSVersion`. May look like `12/08/2017`.

4. SystemManufacturer

Type: plist string

Default value: OEM specified

SMBIOS: System Information (Type 1) — Manufacturer

Description: OEM manufacturer of the particular board. Shall not be specified unless strictly required. Should *not* contain `Apple Inc.`, as this confuses numerous services present in the operating system, such as firmware updates, `eficheck`, as well as kernel extensions developed in `Acidanthera`, such as `Lilu` and its plugins.

5. SystemProductName

Type: plist string

Default value: OEM specified

SMBIOS: System Information (Type 1), Product Name

Description: Preferred Mac model used to mark the device as supported by the operating system. This value must be specified by any configuration for later automatic generation of the related values in this and other SMBIOS tables and related configuration parameters. If `SystemProductName` is not compatible with the target operating system, `-no_compat_check` boot argument may be used as an override.

Note: If `SystemProductName` is unknown, and related fields are unspecified, default values should be assumed as being set to `MacPro6,1` data. The list of known products can be found in `MacInfoPkg`.

6. SystemVersion

- Type:** plist string
Default value: OEM specified
SMBIOS: System Information (Type 1) — Version
Description: Product iteration version number. May look like 1.1.
7. SystemSerialNumber
Type: plist string
Default value: OEM specified
SMBIOS: System Information (Type 1) — Serial Number
Description: Product serial number in defined format. Known formats are described in macserial.
8. SystemUUID
Type: plist string, GUID
Default value: OEM specified
SMBIOS: System Information (Type 1) — UUID
Description: A UUID is an identifier that is designed to be unique across both time and space. It requires no central registration process.
9. SystemSKUNumber
Type: plist string
Default value: OEM specified
SMBIOS: System Information (Type 1) — SKU Number
Description: Mac Board ID (board-id). May look like Mac-7BA5B2D9E42DDD94 or Mac-F221BEC8 in older models. Sometimes it can be just empty.
10. SystemFamily
Type: plist string
Default value: OEM specified
SMBIOS: System Information (Type 1) — Family
Description: Family name. May look like iMac Pro.
11. BoardManufacturer
Type: plist string
Default value: OEM specified
SMBIOS: Baseboard (or Module) Information (Type 2) - Manufacturer
Description: Board manufacturer. All rules of SystemManufacturer do apply.
12. BoardProduct
Type: plist string
Default value: OEM specified
SMBIOS: Baseboard (or Module) Information (Type 2) - Product
Description: Mac Board ID (board-id). May look like Mac-7BA5B2D9E42DDD94 or Mac-F221BEC8 in older models.
13. BoardVersion
Type: plist string
Default value: OEM specified
SMBIOS: Baseboard (or Module) Information (Type 2) - Version
Description: Board version number. Varies, may match SystemProductName or SystemProductVersion.
14. BoardSerialNumber
Type: plist string
Default value: OEM specified
SMBIOS: Baseboard (or Module) Information (Type 2) — Serial Number
Description: Board serial number in defined format. Known formats are described in macserial.
15. BoardAssetTag
Type: plist string
Default value: OEM specified
SMBIOS: Baseboard (or Module) Information (Type 2) — Asset Tag
Description: Asset tag number. Varies, may be empty or Type2 - Board Asset Tag.

16. **BoardType**
Type: plist integer
Default value: OEM specified
SMBIOS: Baseboard (or Module) Information (Type 2) — Board Type
Description: Either 0xA (Motherboard (includes processor, memory, and I/O) or 0xB (Processor/Memory Module), refer to Table 15 – Baseboard: Board Type for more details.
17. **BoardLocationInChassis**
Type: plist string
Default value: OEM specified
SMBIOS: Baseboard (or Module) Information (Type 2) — Location in Chassis
Description: Varies, may be empty or Part Component.
18. **ChassisManufacturer**
Type: plist string
Default value: OEM specified
SMBIOS: System Enclosure or Chassis (Type 3) — Manufacturer
Description: Board manufacturer. All rules of SystemManufacturer do apply.
19. **ChassisType**
Type: plist integer
Default value: OEM specified
SMBIOS: System Enclosure or Chassis (Type 3) — Type
Description: Chassis type, refer to Table 17 — System Enclosure or Chassis Types for more details.
20. **ChassisVersion**
Type: plist string
Default value: OEM specified
SMBIOS: System Enclosure or Chassis (Type 3) — Version
Description: Should match BoardProduct.
21. **ChassisSerialNumber**
Type: plist string
Default value: OEM specified
SMBIOS: System Enclosure or Chassis (Type 3) — Version
Description: Should match SystemSerialNumber.
22. **ChassisAssetTag**
Type: plist string
Default value: OEM specified
SMBIOS: System Enclosure or Chassis (Type 3) — Asset Tag Number
Description: Chassis type name. Varies, could be empty or MacBook-Aluminum.
23. **PlatformFeature**
Type: plist integer
Default value: 0
SMBIOS: APPLE_SMBIOS_TABLE_TYPE133 - PlatformFeature
Description: Platform features bitmask. Refer to AppleFeatures.h for more details.
24. **FirmwareFeatures**
Type: plist data, 8 bytes
Default value: 0
SMBIOS: APPLE_SMBIOS_TABLE_TYPE128 - FirmwareFeatures and ExtendedFirmwareFeatures
Description: 64-bit firmware features bitmask. Refer to AppleFeatures.h for more details. Lower 32 bits match FirmwareFeatures. Upper 64 bits match ExtendedFirmwareFeatures.
25. **FirmwareFeaturesMask**
Type: plist data, 8 bytes
Default value: 0
SMBIOS: APPLE_SMBIOS_TABLE_TYPE128 - FirmwareFeaturesMask and ExtendedFirmwareFeaturesMask
Description: Supported bits of extended firmware features bitmask. Refer to AppleFeatures.h for more details. Lower 32 bits match FirmwareFeaturesMask. Upper 64 bits match ExtendedFirmwareFeaturesMask.

- 26. ProcessorType
 - Type:** plist integer, 16-bit
 - Default value:** Automatic
 - SMBIOS:** APPLE_SMBIOS_TABLE_TYPE131 - ProcessorType
 - Description:** Combined of Processor Major and Minor types.

- 27. MemoryFormFactor
 - Type:** plist integer, 8-bit
 - Default value:** OEM specified
 - SMBIOS:** Memory Device (Type 17) — Form Factor
 - Description:** Memory form factor. On Macs it should be DIMM or SODIMM.

10 UEFI

10.1 Introduction

UEFI (Unified Extensible Firmware Interface) is a specification that defines a software interface between an operating system and platform firmware. This section allows to load additional UEFI modules and/or apply tweaks for the onboard firmware.

10.2 Properties

1. ConnectDrivers

Type: plist boolean

Default value: NO

Description: Perform UEFI controller connection after driver loading. This option is useful for loading filesystem drivers, which usually follow UEFI driver model, and may not start by themselves. While effective, this option is not necessary with e.g. APFS loader driver, and may slightly slowdown the boot.

2. Drivers

Type: plist array

Default value: None

Description: Load selected drivers from `OC/Drivers` directory.

Designed to be filled with string filenames meant to be loaded as UEFI drivers. Depending on the firmware a different set of drivers may be required. Loading an incompatible driver may lead your system to unbootable state or even cause permanent firmware damage. Some of the known drivers include:

- **ApfsDriverLoader** — APFS file system bootstrap driver adding the support of embedded APFS drivers in bootable APFS containers in UEFI firmwares.
- **AppleUiSupport** — Apple-specific user interface support driver. This driver brings the support for FileVault 2 GUI, hotkey parsing (shift, cmd+v, etc.), language collation support, and certain other features important for normal macOS functioning. For hotkey support **AppleKeyMapAggregator**-compatible driver is required.
- **AptioInputFix** — user input driver adding the support of **AppleKeyMapAggregator** protocols on top of different UEFI input protocols. Additionally resolves mouse input issues on select firmwares. This is an alternative to **UsbKbDxe**, which may work better or worse depending on the firmware.
- **AptioMemoryFix** — a set of quirks for various firmwares. While it primarily targets APTIO firmwares, other firmwares may be compatible as well. Among the resolved issues are hibernation support, KASLR, Lilu NVRAM security enhancements, NVRAM, and UEFI Boot entry preservation.
- **DataHubDxe** — Intel DataHub driver from **IntelFrameworkModulePkg**. It is believed that this driver is included in all UEFI firmwares, and is not required.
- **EmuVariableRuntimeDxe** — NVRAM emulation driver from **MdeModulePkg**. NVRAM is supported by most modern firmwares. For firmwares with macOS incompatible NVRAM implementation an emulated driver may be used. This driver will not preserve NVRAM contents across the reboots.
- **EnglishDxe** — Unicode collation driver from **MdeModulePkg**. This driver is a lightweight alternative to **AppleUiSupport**, which contains no Apple-specific code, and only provides unicode collation support. The driver is not recommended for use on any hardware but few original Macs.
- **EnhancedFatDxe** — FAT filesystem driver from **FatPkg**. This driver is embedded in all UEFI firmwares, and cannot be used from OpenCore. It is known that multiple firmwares have a bug in their FAT support implementation, which leads to corrupted filesystems on write attempt. Embedding this driver within the firmware may be required in case writing to EFI partition is needed during the boot process.
- **NvmExpressDxe** — NVMe support driver from **MdeModulePkg**. This driver is included in most firmwares starting with Broadwell generation. For Haswell and earlier embedding it within the firmware may be more favourable in case a NVMe SSD drive is installed.
- **UsbKbDxe** — USB keyboard driver adding the support of **AppleKeyMapAggregator** protocols on top of a custom USB keyboard driver implementation. This is an alternative to **AptioInputFix**, which may work better or worse depending on the firmware.
- **VirtualSmc** — UEFI SMC driver, required for proper FileVault 2 functionality and potentially other macOS specifics. An alternative, named **SMCHelper**, is not compatible with **VirtualSmc** and OpenCore, which is unaware of its specific interfaces. In case **FakeSMC** kernel extension is used, manual NVRAM variable addition may be needed and **VirtualSmc** driver should still be used.

- `VBoxHfs` — HFS file system driver with bless support. This driver is an alternative to a closed source `HFSPPlus` driver commonly found in Apple firmwares. While it is feature complete, it is approximately 3 times slower and is yet to undergo a security audit.
- `XhciDxe` — XHCI USB controller support driver from `MdeModulePkg`. This driver is included in most firmwares starting with Sandy Bridge generation. For earlier firmwares or legacy systems it may be used to support external USB 3.0 PCI cards.

To compile the drivers from Tianocore UDK use the same command you do normally use for OpenCore compilation, but choose a corresponding package:

```
git clone https://github.com/tianocore/edk2 -b UDK2018 UDK
cd UDK
source edksetup.sh
make -C BaseTools
build -a X64 -b RELEASE -t XCODE5 -p FatPkg/FatPkg.dsc
build -a X64 -b RELEASE -t XCODE5 -p MdeModulePkg/MdeModulePkg.dsc
build -a X64 -b RELEASE -t XCODE5 -p IntelFrameworkModulePkg/IntelFrameworkModulePkg.dsc
```

3. Protocols

Type: plist dict

Default value: None

Description: Force builtin versions of select protocols described in Protocols Properties section below.

4. Quirks

Type: plist dict

Default value: None

Description: Apply individual firmware quirks described in Quirks Properties section below.

10.3 Protocols Properties

1. AppleBootPolicy

Type: plist boolean

Default value: false

Description: Reinstalls apple boot policy protocol with a builtin version. This may be used to ensure APFS compatibility on VMs or legacy Macs.

2. DeviceProperties

Type: plist boolean

Default value: false

Description: Reinstalls device property protocol with a builtin version. This will drop all previous properties if it was already installed. This may be used to ensure full compatibility on VMs or legacy Macs.

10.4 Quirks Properties

1. ExitBootServicesDelay

Type: plist integer

Default value: 0

Description: Adds delay in microseconds after `EXIT_BOOT_SERVICES` event.

This is a very ugly quirk to circumvent "Still waiting for root device" message on select APTIO IV firmwares, namely ASUS Z87-Pro, when using FileVault 2 in particular. It seems that for some reason they execute code in parallel to `EXIT_BOOT_SERVICES`, which results in SATA controller being inaccessible from macOS. A better approach should be found in some future. Expect 3-5 seconds to be enough in case the quirk is needed.

2. IgnoreInvalidFlexRatio

Type: plist boolean

Default value: NO

Description: Select firmwares, namely APTIO IV, may contain invalid values in `MSR_FLEX_RATIO` (0x194) MSR register. These values may cause macOS boot failure on Intel platforms.

Note: While the option is not supposed to induce harm on unaffected firmwares, its usage is not recommended when it is not required.

3. IgnoreTextInGraphics

Type: plist boolean

Default value: NO

Description: Select firmwares output text onscreen in both graphics and text mode. This is normally unexpected, because random text may appear over graphical images and cause UI corruption. Setting this option to `true` will discard all text output when console control is in mode different from `Text`.

Note: While the option is not supposed to induce harm on unaffected firmwares, its usage is not recommended when it is not required. This option may hide onscreen error messages. `ProvideConsoleControl` is required to be set to `true` for this to work.

4. ProvideConsoleControl

Type: plist boolean

Default value: NO

Description: macOS bootloader requires console control protocol for text output, some firmwares miss it. This option is required to be set when other console control options are used, such as `IgnoreTextInGraphics`, `SanitiseClearScreen`, and sometimes `ConsoleBehaviourOs` with `ConsoleBehaviourUi`).

5. ProvideConsoleGop

Type: plist boolean

Default value: NO

Description: macOS bootloader requires GOP (Graphics Output Protocol) to be present on console handle. This option will install it if missing.

Note: Some drivers, like `AptioMemoryFix`, may provide equivalent functionality. These drivers are not guaranteed to adhere to the same logic, and if a quirk is necessary, this option is preferred.

6. ReleaseUsbOwnership

Type: plist boolean

Default value: false

Description: Attempt to detach USB controller ownership from the firmware driver. While most firmwares manage to properly do that, or at least have an option for, select firmwares do not. As a result, operating system may freeze upon boot. Not recommended unless required.

7. RequestBootVarRouting

Type: plist boolean

Default value: false

Description: Request NVRAM driver (or `AptioMemoryFix`) to redirect `Boot` prefixed variables from `EFI_GLOBAL_VARIABLE_GUID` to `OC_VENDOR_VARIABLE_GUID`.

This will set special `boot-redirect` variable, which a compatible driver will abide after booter start. The quirk lets default boot entry preservation at times when firmwares delete incompatible boot entries.

8. SanitiseClearScreen

Type: plist boolean

Default value: false

Description: Some firmwares reset screen resolution to a failsafe value (like 1024x768) on the attempts to clear screen contents when large display (e.g. 2K or 4K) is used. This option attempts to apply a workaround.

Note: `ProvideConsoleControl` is required to be set to `true` for this to work. On all known affected systems `ConsoleMode` had to be set to empty string for this to work.

11 Troubleshooting

11.1 Tips and Tricks

1. How to debug boot failure?

Normally it is enough to obtain the actual error message. For this ensure that:

- You have a `DEBUG` or `NOOPT` version of OpenCore.
- Logging is enabled (1) and shown onscreen (2): `Misc → Debug → Target = 3`.
- Logged messages from at least `DEBUG_ERROR` (`0x80000000`), `DEBUG_WARN` (`0x00000002`), and `DEBUG_INFO` (`0x00000040`) levels are visible onscreen: `Misc → Debug → DisplayLevel = 0x80000042`.
- Critical error messages, like `DEBUG_ERROR`, stop booting: `Misc → Security → HaltLevel = 0x80000000`.
- Watch Dog is disabled to prevent automatic reboot: `Uefi → Quirks → DisableWatchDog = true`.
- Boot Picker (entry selector) is enabled: `Misc → Boot → ShowPicker = true`.

If there is no obvious error, check the available hacks in `Quirks` sections one by one.

2. How to customise boot entries?

OpenCore follows standard Apple Bless model and extracts the entry name from `.contentDetails` and `.disk_label.contentDetails` files in the booter directory if present. These files contain an ASCII string with an entry title, which may then be customised by the user.

3. What is the simplest way to install macOS?

Copy online recovery image (`*.dmg` and `*.chunklist` files) to `com.apple.recovery.boot` directory on a FAT32 partition with OpenCore. Load OpenCore Boot Picker and choose the entry, it will have a `(dmg)` suffix. Custom name may be created by providing `.contentDetails` file.

To download recovery online you may use Recovery tool from `OcSupportPkg`.